

BOMBAS SUMERGIBLES

Presión de altura



bombaparaagua.com.mx

BOMBAS SUMERGIBLES

FUENTE Y ORNATO



CISTERNA



POZO PROFUNDO



ACHIQUE





- Motores de magnetos permanentes extra eficientes: muy bajo consumo energético, para uso continuo.
- Ideal para la recirculación de agua en fuentes y acuarios.
- Caídas y cortinas de agua.
- Incluye adaptador para manguera.



AQUA3W

AQUA18W

AQUA45W

AQUA60W

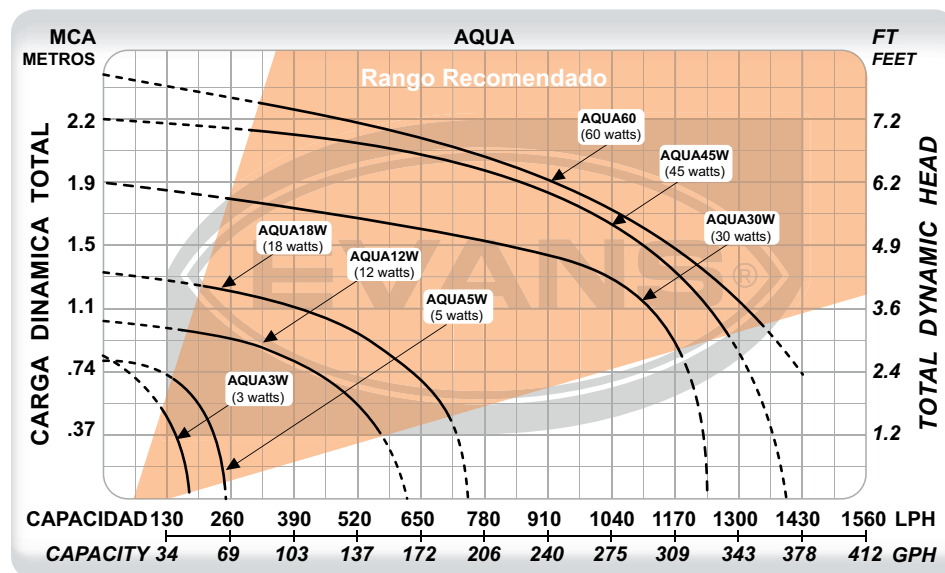

CÓDIGO	PESO	MEDIDAS LARGO x ANCHO x ALTO
AQUA3W	0.25 kg	7 x 7 x 12 cm
AQUA5W	0.30 kg	11 x 9 x 8 cm
AQUA12W	0.44 kg	12 x 10 x 8 cm
AQUA18W	0.48 kg	12 x 10 x 9 cm
AQUA30W	0.86 kg	13 x 12 x 11 cm
AQUA45W	1.06 kg	16 x 11 x 12 cm
AQUA60W	1.76 kg	19 x 15 x 13 cm

CÓDIGO	Ø DESCARGA	POTENCIA	VOLTAJE	CORRIENTE	FLUJO MÁXIMO	PRESIÓN MÁXIMA	PUNTO DE MAYOR EFICIENCIA
AQUA3W	1/4"	3W	127 V ~ 60Hz 1Φ	5 mA	177 l/h	0.79 m	130 l/h a 0.5 m
AQUA5W	1/4"	5W	127 V ~ 60Hz 1Φ	65 mA	258 l/h	0.76 m	180 l/h a 0.7 m
AQUA12W	1/4"	12W	127 V ~ 60Hz 1Φ	89 mA	612 l/h	1.08 m	450 l/h a 0.75 m
AQUA18W	1/4"	18W	127 V ~ 60Hz 1Φ	179 mA	766 l/h	1.38 m	650 l/h a 0.75 m
AQUA30W	1/2"	30W	127 V ~ 60Hz 1Φ	490 mA	1236 l/h	1.99 m	1000 l/h a 1.3 m
AQUA45W	1/2"	45W	127 V ~ 60Hz 1Φ	680 mA	1422 l/h	2.20 m	1050 l/h a 1.5 m
AQUA60W	3/4"	60W	127 V ~ 60Hz 1Φ	1 A	1980 l/h	2.46 m	1100 l/h a 1.5 m

Belleza bajo el agua



AQUA120W-F



AQUA200W-F

- Motores de magnetos permanentes extra eficientes: muy bajo consumo energético, para uso continuo.
- Ideal para la recirculación de agua en fuentes y acuarios.
- Óptimas para muros llorones.
- Incluye adaptador para manguera.

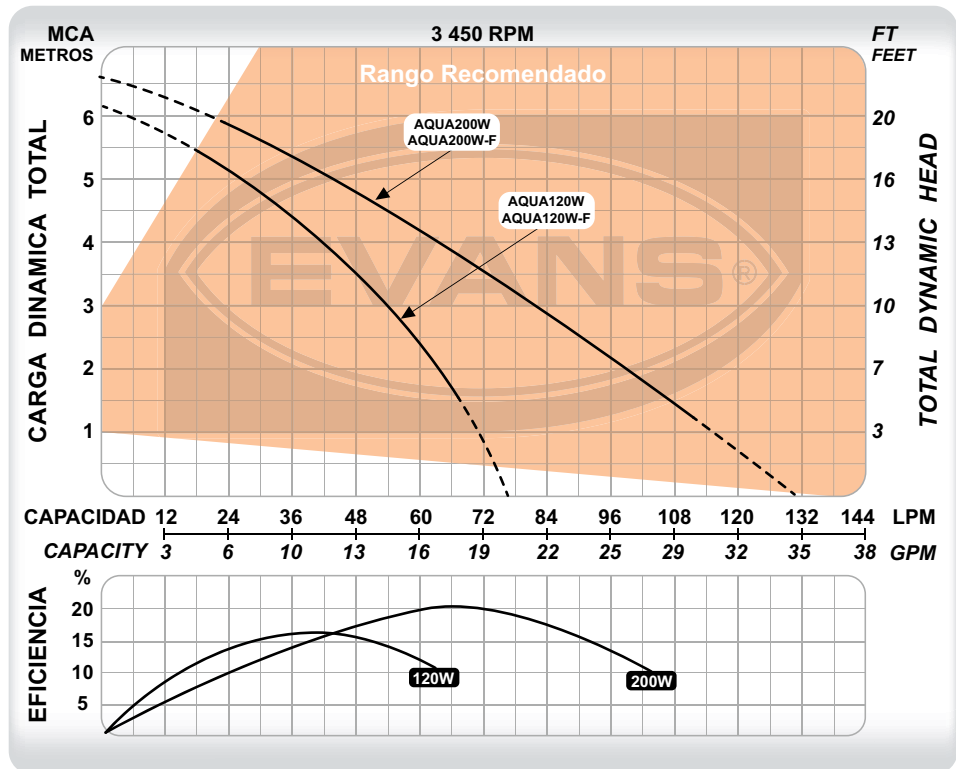

CÓDIGO	PESO	MEDIDAS LARGO x ANCHO x ALTO
AQUA120W	3.1 kg	17 x 17 x 28 cm
AQUA120W-F	3.3 kg	17 x 17 x 28 cm
AQUA200W	4.2 kg	16 x 16 x 30 cm
AQUA200W-F	4.5 kg	16 x 16 x 30 cm

CÓDIGO	Ø DESCARGA	POTENCIA	VOLTAJE	CORRIENTE	FLUJO MÁXIMO	PRESIÓN MÁXIMA	PUNTO DE MAYOR EFICIENCIA
AQUA120W	1"	120W	115 V ~ 60Hz 1Φ	2.1 A	73 l/min	6m	40 l/ min a 5 m
AQUA120W-F	1"	120W	115 V ~ 60Hz 1Φ	2.1 A	73 l/min	6 m	40 l/ min a 5 m
AQUA200W	1 ¼"	200W	115 V ~ 60Hz 1Φ	2.4 A	129 l/min	6.5 m	65 l/ min a 5 m
AQUA200W-F	1 ¼"	200W	115 V ~ 60Hz 1Φ	2.4 A	129 l/min	6.5 m	65 l/ min a 5 m

1
año
GARANTÍA



NOM

- Creación de juegos de agua y fuentes de ornato.
- Incluye todos los accesorios necesarios para crear diferentes estilos de fuente.
- Motores de magnetos permanentes extra eficientes: muy bajo consumo energético, para uso continuo.



CUETE



LLUVIA



ESPUMA



MARTINI



HONGO

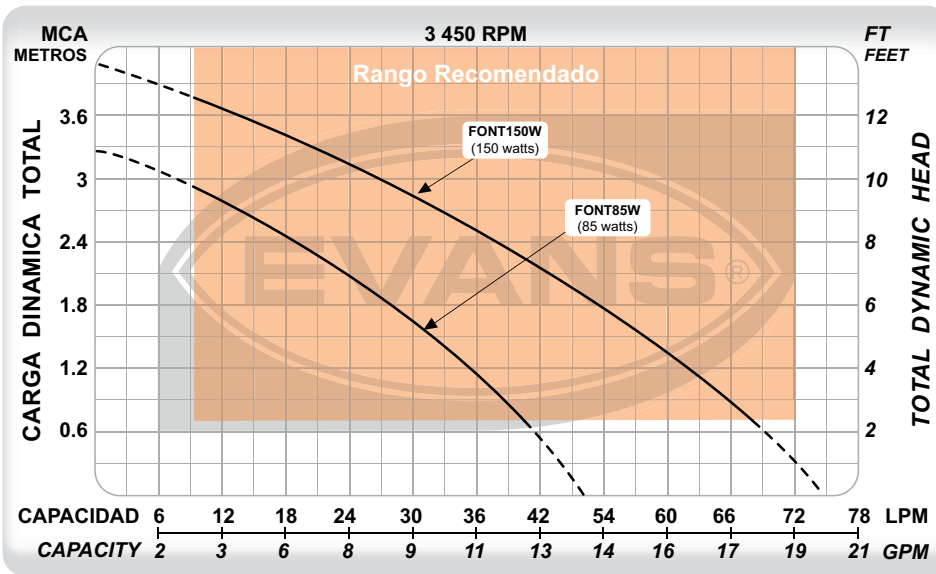

CÓDIGO	PESO	MEDIDAS LARGO x ANCHO x ALTO
FONT85W	2.3 kg	22 x 20 x 15 cm
FONT150W	3.57 kg	24 x 21 x 15 cm

CÓDIGO	Ø DESCARGA	POTENCIA	VOLTAJE	CORRIENTE	FLUJO MÁXIMO	PRESIÓN MÁXIMA	PUNTO DE MAYOR EFICIENCIA
FONT85W	3/4"	85 W	127 V ~ 60Hz 1Ø	1.2 A	46 l/min	3.19 m	27 l/min a 1.8 m
FONT150W	3/4"	150 W	127 V ~ 60Hz 1Ø	1.84 A	74 l/min	3.93 m	27 l/min a 3 m



CLASE 1G

CISTERNA DOMÉSTICA

Abastecimiento de agua confiable

NOM



1
año
GARANTÍA



- La de mayor presión en su categoría. 50% más altura que la competencia.
- Ideal para el rápido llenado de tinacos de manera totalmente silenciosa.
- Uso exclusivo con agua limpia.
- Anticorrosiva por sus materiales en plástico.



DIAGRAMA DE INSTALACIÓN

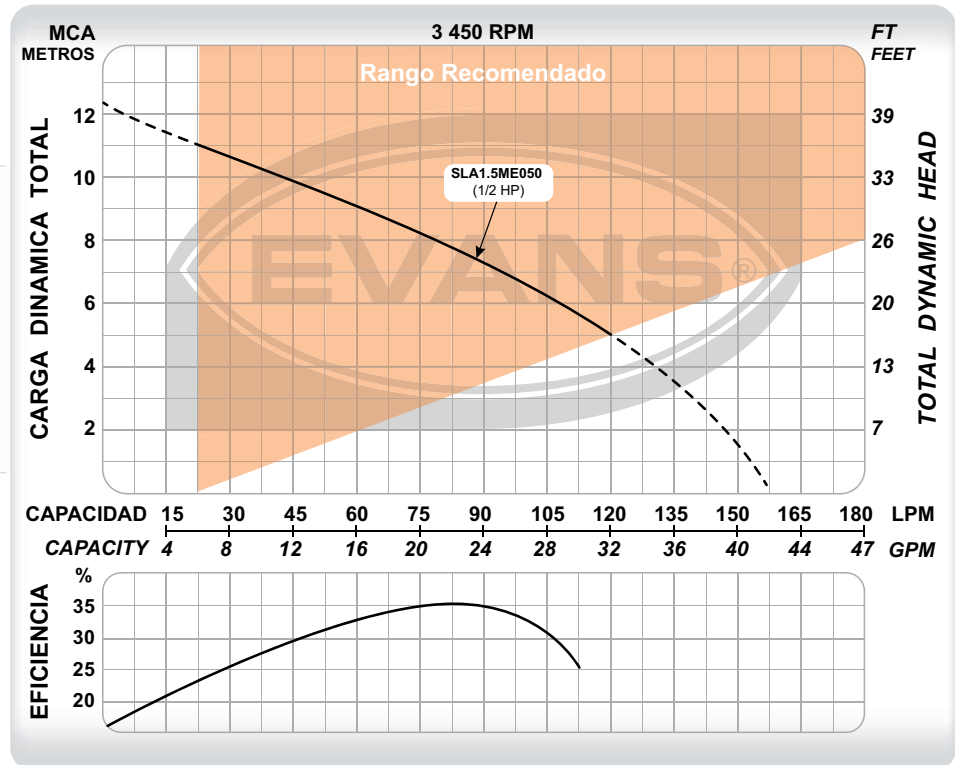

CÓDIGO **PESO** **MEDIDAS**
LARGO x ANCHO x ALTO

SLA1.5ME050 6 kg 22 x 16 x 36 cm

CÓDIGO	Ø DESCARGA	POTENCIA	VOLTAJE	CORRIENTE	FLUJO MÁXIMO	PRESIÓN MÁXIMA	PUNTO DE MAYOR EFICIENCIA
SLA1.5ME050	1 ½"	1/2 HP	115V ~ 60Hz 1Φ	4.2 A	158 l/min	12 m	90 l/min a 7.5 m

CISTERNA DOMÉSTICAS

Abastecimiento de agua confiable



CLASE 1G

1
año
GARANTÍA



NOM

- Equipo altamente eficiente: excelente altura y flujo con bajo consumo energético.
- Ideales para el rápido llenado de tinacos de manera totalmente silenciosa.
- Uso exclusivo con agua limpia.
- Extra resistente por sus materiales en hierro gris.



SELECCIONA TU MOTOBOMBA SUMERGIBLE							
CONSUMO ESTIMADO DE 300 LITROS DE GASTO AL DÍA POR PERSONA	NÚMERO PERSONAS	2i	4i	6i	10i	PARA SELECCIONAR EL DIÁMETRO DE LA TUBERÍA CONSULTE LAS TABLAS DE PERDIDA POR FRICIÓN.	
CAPACIDAD EN LITROS EN TINACO		600	1100	2200	3300		
CASA HABITACIÓN	# de Pisos	1/2hp	1/2hp	3/4hp	3/4hp	Ø DE TUBERÍA CAPACIDAD EN LITROS X MIN. *1/2" Tubería NO recomendada 0-15 *3/4" Tubería NO recomendada 0-35 1" 0-60 1 1/4" 0-95	
	6 metros	1	6min.	10min.	18min.		28min.
	9 metros	2	1/2hp	1/2hp	3/4hp		1hp
	12 metros	3	3/4hp	3/4hp	1hp	1hp	
			7min.	13min.	17min.	25min.	

⌚ Tiempo de llenado



DIAGRAMA DE INSTALACIÓN

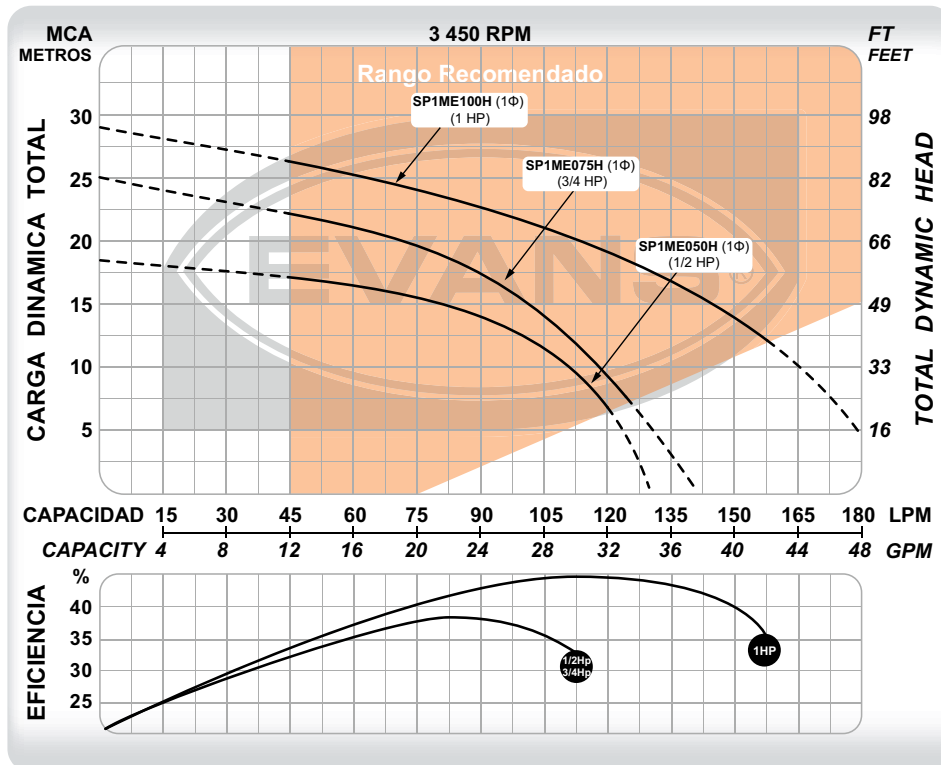

CÓDIGO	PESO	MEDIDAS LARGO x ANCHO x ALTO
SP1ME050H	11 kg	40 x 19 x 10 cm
SP1ME075H	14 kg	41 x 23 X 22 cm
SP1ME100H	17 kg	41 x 23 X 22 cm

CÓDIGO	Ø DESCARGA	POTENCIA	VOLTAJE	CORRIENTE	FLUJO MÁXIMO	PRESIÓN MÁXIMA	PUNTO DE MAYOR EFICIENCIA
SP1ME050H	1"	1/2 HP	127 V ~ 60Hz 1Φ	6.5 A	130 l/min	19 m	85 l/min a 15 m
SP1ME075H	1"	3/4 HP	127 V ~ 60Hz 1Φ	8.5 A	140 l/min	25 m	85 l/min a 18 m
SP1ME100H	1"	1 HP	127 V ~ 60Hz 1Φ	10.5 A	190 l/min	29.5 m	120 l/min a 18 m

Disfruta la presión del agua

NOM



1
año
GARANTÍA



- Opción versátil para la presurización en casas de hasta 3 niveles.
- Ideales para sistemas de presión con hidroneumático y/ó Easy-press®.
- Extra resistente por sus materiales en hierro gris y acero inoxidable.



DIAGRAMA DE INSTALACIÓN



CÓDIGO	PESO	MEDIDAS LARGO x ANCHO x ALTO
SPM1ME075F-F	9 kg	45 x 18 x 22 cm
SPM1ME100F-F	10 kg	50 x 18 x 22 cm

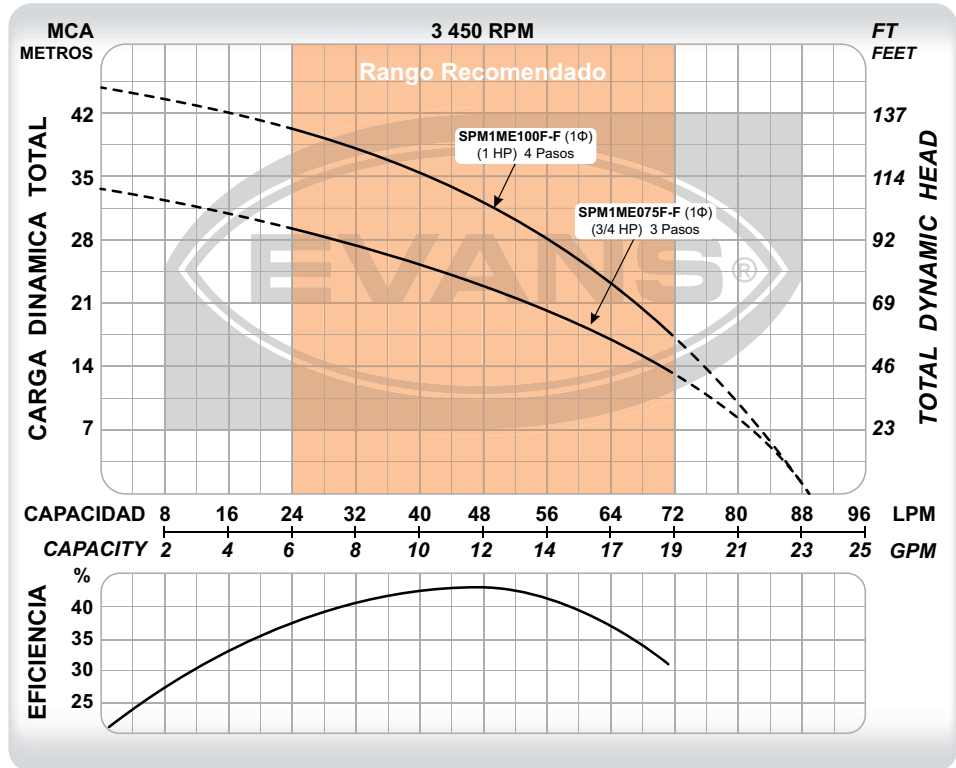

CÓDIGO	Ø DESCARGA	POTENCIA	VOLTAJE	CORRIENTE	ETAPAS	FLUJO MÁXIMO	PRESIÓN MÁXIMA	PUNTO DE MAYOR EFICIENCIA
SPM1ME075F-F	1"	3/4 HP	115 V ~ 60Hz 1Φ	6.9 A	3	90 l/min	33 m	48 l/min a 23 m
SPM1ME100F-F	1"	1 HP	115 V ~ 60Hz 1Φ	9 A	4	90 l/min	45 m	48 l/min a 32 m

POZO PROFUNDO 3" | 10 GPM

Desempeño de altura

CLASE II



1
año
GARANTÍA



- Bomba sumergible de 3".
- Especialmente útil para extraer agua de pozos estrechos, chuecos o de difícil acceso.
- Motor monofásico muy sencillo de instalar: no necesita caja de control.
- Impulsores tipo flotantes fabricados en Noryl®.

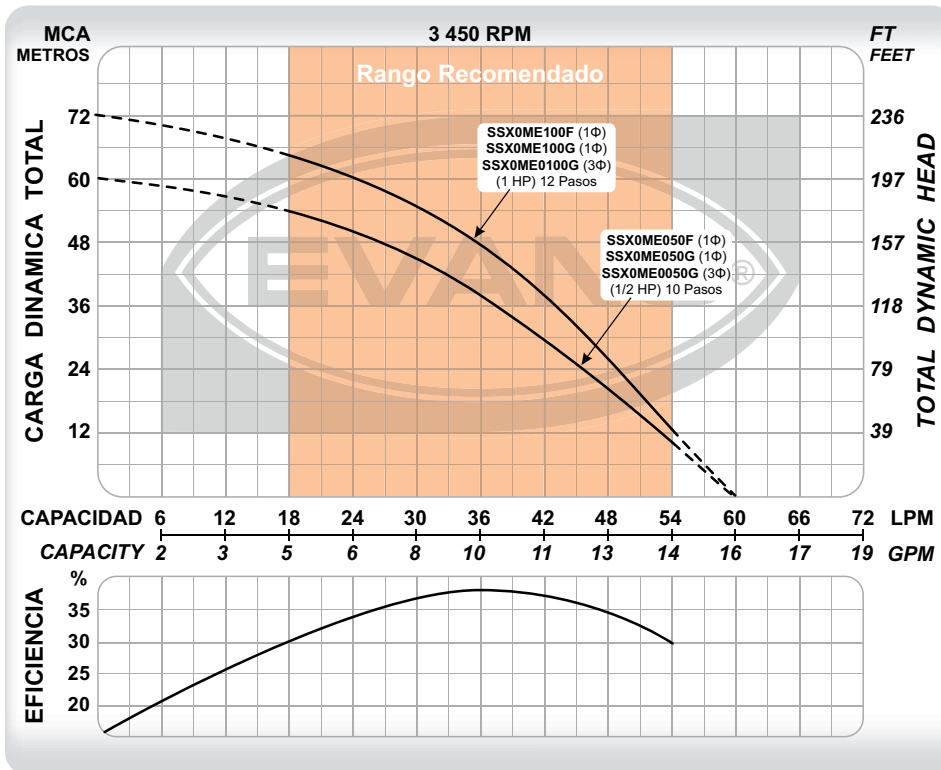

CÓDIGO	PESO	MEDIDAS LARGO x ANCHO x ALTO
SSX0ME050F	8.5 kg	96 x 15 x 23 cm
SSX0ME050G	8.5 kg	96 x 15 x 23 cm
SSX0ME100F	9.5 kg	102 x 15 x 23 cm
SSX0ME100G	9.5 kg	102 x 15 x 23 cm
SSX0ME0050G	8.5 kg	96 x 15 x 23 cm
SSX0ME0100G	9.5 kg	102 x 15 x 23 cm

CÓDIGO	Ø DESCARGA	POTENCIA	VOLTAJE	CORRIENTE	ETAPAS	FLUJO MÁXIMO	PRESIÓN MÁXIMA	PUNTO DE MAYOR EFICIENCIA
SSX0ME050F	1"	1/2 HP	115 V ~ 60Hz 1Φ	7.4 A	10	60 l/min	60 m	36 l/min a 40 m
SSX0ME050G	1"	1/2 HP	220 V ~ 60Hz 1Φ	3.7 A	10	60 l/min	60 m	36 l/min a 40 m
SSX0ME100F	1"	1 HP	115 V ~ 60Hz 1Φ	9 A	12	60 l/min	72 m	36 l/min a 48 m
SSX0ME100G	1"	1 HP	220 V ~ 60Hz 1Φ	4.5 A	12	60 l/min	72 m	36 l/min a 48 m
SSX0ME0050G	1"	1/2 HP	220 V ~ 60Hz 3Φ	2.5 A	10	60 l/min	60 m	36 l/min a 40 m
SSX0ME0100G	1"	1 HP	220 V ~ 60Hz 3Φ	3.5 A	12	60 l/min	72 m	36 l/min a 48 m

CISTERNA RESIDENCIAL O POZOS PROFUNDOS

Disfruta la presión del agua

NOM



1
año
GARANTÍA



- Modelos con flotador: ideales para presurizar residencias o pequeños comercios con hidroneumático y/ó Easy-press®.
- Modelos sin flotador: ideales para extracción de agua en pozos desde 4" de ademe. Motor de 2 hilos muy sencillo de instalar: no necesita caja de control.
- Succión inferior para el máximo aprovechamiento del volumen total de agua dentro de la cisterna.
- Impulsores tipo flotantes fabricados en Noryl®.



INSTALACIÓN PARA HIDRONEUMÁTICO



CÓDIGO	PESO	MEDIDAS LARGO x ANCHO x ALTO
SSX1ME050F2C	13 kg	71 x 15 x 15 cm
SSX1ME050F2C-F	13 kg	71 x 15 x 15 cm
SSX1ME100F2C	14.5 kg	76 x 15 x 15 cm
SSX1ME100F2C-F	14.5 kg	76 x 15 x 15 cm
SSX1ME100G2C	14.5 kg	76 x 15 x 15 cm
SSX1ME100G2C-F	14.5 kg	76 x 15 x 15 cm
SSX1ME0100G	14.5 kg	76 x 15 x 15 cm

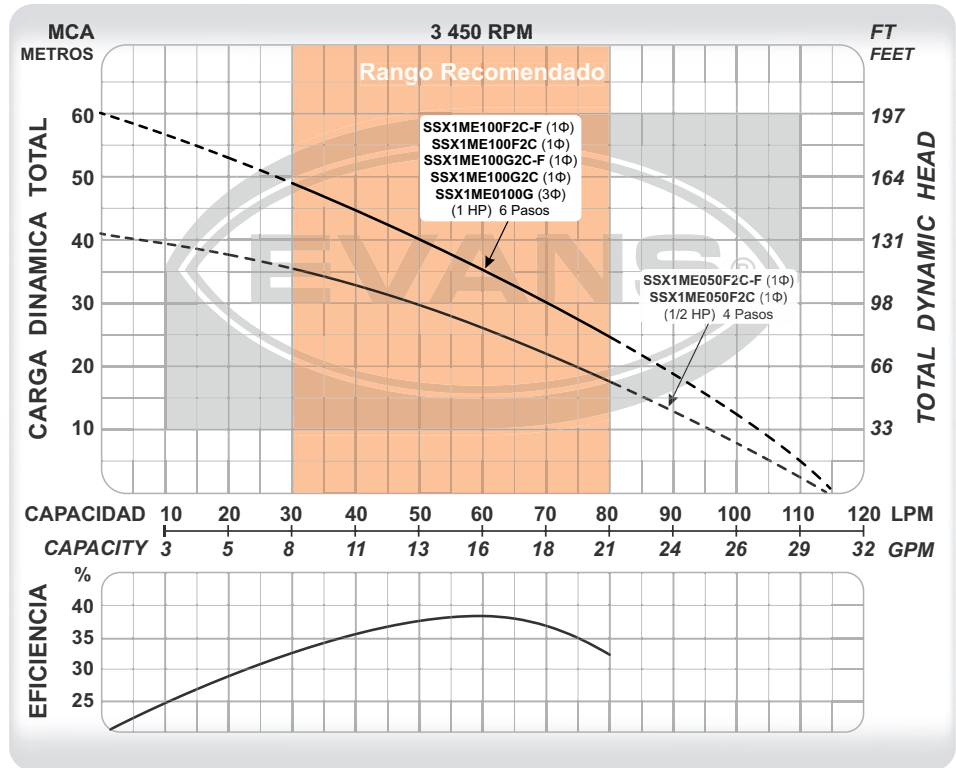

CÓDIGO	Ø DESCARGA	POTENCIA	VOLTAJE	CORRIENTE	ETAPAS	FLUJO MÁXIMO	PRESIÓN MÁXIMA	PUNTO DE MAYOR EFICIENCIA
SSX1ME050F2C	1 ¼"	1/2 HP	115 V ~ 60Hz 1Φ	8.8 A	4	115 l/min	41 m	60 l/min a 26 m
SSX1ME050F2C-F	1 ¼"	1/2 HP	115 V ~ 60Hz 1Φ	8.8 A	4	115 l/min	41 m	60 l/min a 26 m
SSX1ME100F2C	1 ¼"	1 HP	115 V ~ 60Hz 1Φ	12.5 A	6	115 l/min	61 m	60 l/min a 35 m
SSX1ME100F2C-F	1 ¼"	1 HP	115 V ~ 60Hz 1Φ	12.5 A	6	115 l/min	61 m	60 l/min a 35 m
SSX1ME100G2C	1 ¼"	1 HP	220 V ~ 60Hz 1Φ	6.3 A	6	115 l/min	61 m	60 l/min a 35 m
SSX1ME100G2C-F	1 ¼"	1 HP	220 V ~ 60Hz 1Φ	6.3 A	6	115 l/min	61 m	60 l/min a 35 m
SSX1ME0100G	1 ¼"	1 HP	220 V ~ 60Hz 3Φ	4.2 A	6	115 l/min	61 m	60 l/min a 35 m

CISTERNA RESIDENCIAL

Disfruta la presión del agua

CLASE II



1
año
GARANTÍA



NOM

- Bomba automática con electrónica integrada.
- Equivalente a instalar una SSX1 con Easy-press®.
- Puede instalarse con un pequeño tanque hidroneumático.
- Succión inferior para el máximo aprovechamiento del volumen total de agua dentro de la cisterna.

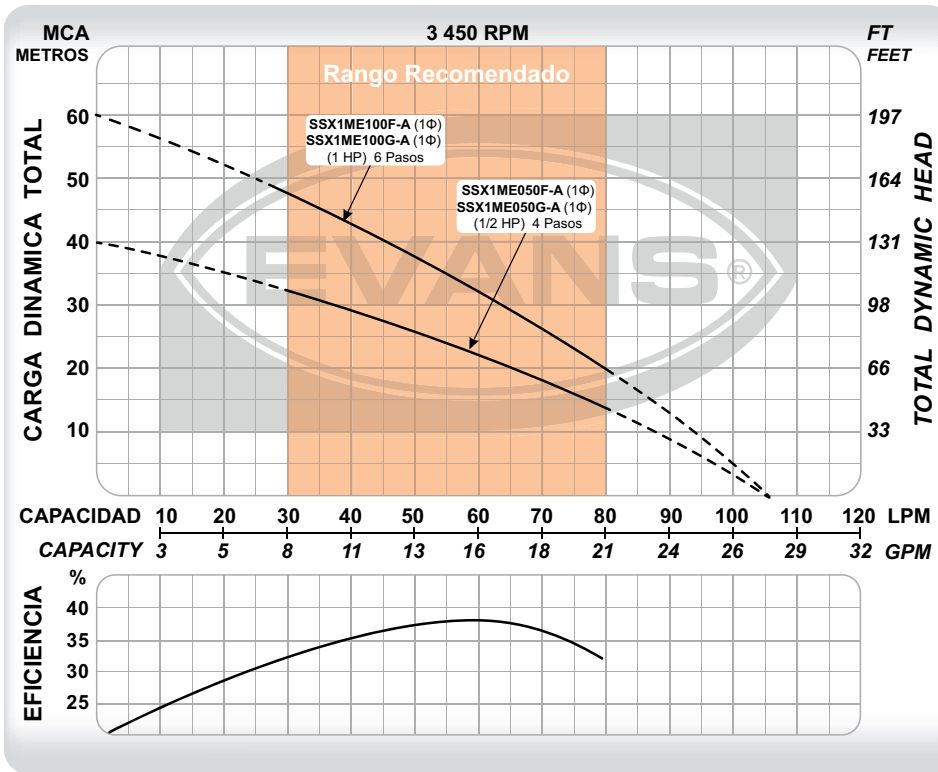
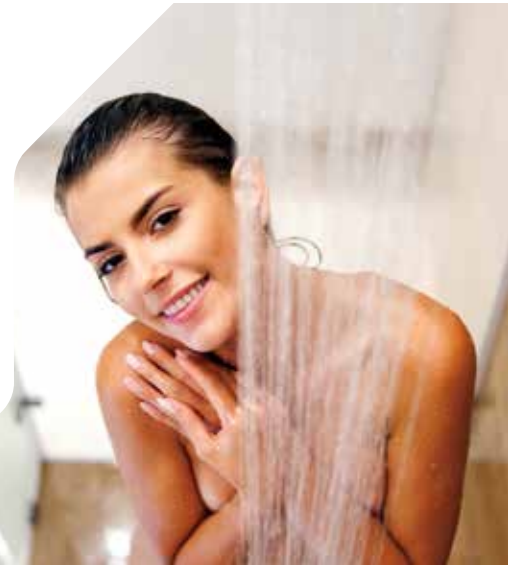

CÓDIGO	PESO	MEDIDAS LARGO x ANCHO x ALTO
SSX1ME050F-A	8,5 kg	80 x 15 x 23 cm
SSX1ME100F-A	10 kg	97 x 15 x 23 cm
SSX1ME050G-A	8,5 kg	80 x 15 x 23 cm
SSX1ME100G-A	10 kg	97 x 15 x 23 cm

CÓDIGO	Ø DESCARGA	POTENCIA	VOLTAJE	CORRIENTE	ETAPAS	FLUJO MÁXIMO	PRESIÓN MÁXIMA	PUNTO DE MAYOR EFICIENCIA
SSX1ME050F-A	1"	1/2 HP	115 V ~ 60Hz 1Φ	8.8 A	4	105 l/min	40 m	60 l/min a 25 m
SSX1ME100F-A	1"	1 HP	115 V ~ 60Hz 1Φ	12.5 A	6	105 l/min	60 m	60 l/min a 34 m
SSX1ME050G-A	1"	1/2 HP	220 V ~ 60Hz 1Φ	4.4 A	4	105 l/min	40 m	60 l/min a 25 m
SSX1ME100G-A	1"	1 HP	220 V ~ 60Hz 1Φ	6.3 A	6	105 l/min	60 m	60 l/min a 34 m



CLASE II

POZO PROFUNDO 4" | 18 GPM

Desempeño de altura



1
año
GARANTÍA



- Ideal para extraer agua de pozos de 4" de ademe y hasta 100m de profundidad.
- Motor de 2 hilos muy sencillo de instalar: no necesita caja de control.
- Impulsores tipo flotantes fabricados en Noryl®.

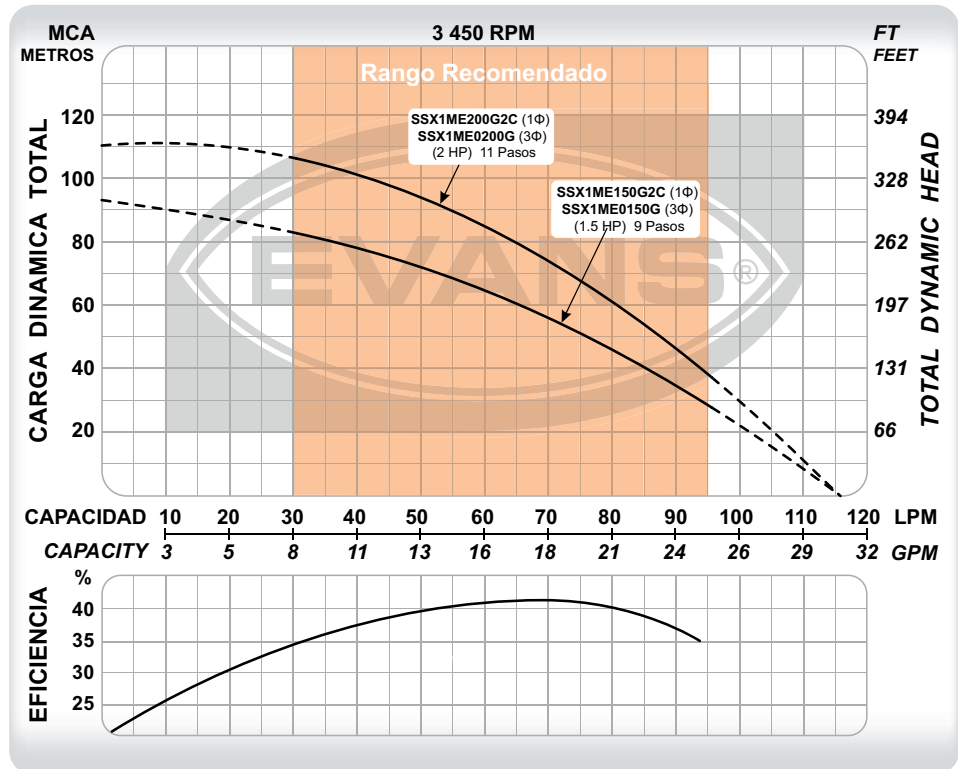

CÓDIGO	PESO	MEDIDAS LARGO x ANCHO x ALTO
SSX1ME150G2C	11 kg	103 x 15 X 14 cm
SSX1ME200G2C	12 kg	114 x 15 x 14 cm
SSX1ME0150G	11 kg	97 x 15 x 14 cm
SSX1ME0200G	12 kg	107 x 15 x 14 cm

CÓDIGO	Ø DESCARGA	POTENCIA	VOLTAJE	CORRIENTE	ETAPAS	FLUJO MÁXIMO	PRESIÓN MÁXIMA	PUNTO DE MAYOR EFICIENCIA
SSX1ME150G2C	1 ¼"	1.5 HP	220 V ~ 60Hz 1Φ	9 A	9	115 l/min	91 m	70 l/min a 55 m
SSX1ME200G2C	1 ¼"	2 HP	220 V ~ 60Hz 1Φ	12 A	11	115 l/min	110 m	70 l/min a 72 m
SSX1ME0150G	1 ¼"	1.5 HP	220 V ~ 60Hz 3Φ	6 A	9	115 l/min	91 m	70 l/min a 55 m
SSX1ME0200G	1 ¼"	2 HP	220 V ~ 60Hz 3Φ	8 A	11	115 l/min	110 m	70 l/min a 72 m

1
año
GARANTÍA



- Equipo ideal para la presurización de comercios ó pequeñas industrias.
- Excelente opción para instalarse en equipos multibomba con variadores de frecuencia.
- Succión inferior para el máximo aprovechamiento del volumen total de agua dentro de la cisterna.
- Impulsores fabricados en acero inoxidable 304.



LAS BOMBAS MONOFÁSICAS: ·220 V INCLUYEN FLOTADOR | ·115 V INCLUYEN CAJA DE CONTROL



DIAGRAMA DE INSTALACIÓN PARA HIDRONEUMÁTICO



CÓDIGO **PESO** **MEDIDAS**
LARGO x ANCHO x ALTO

CÓDIGO	PESO	MEDIDAS
SSX4ME100F3-I	14 kg	60 x 20 x 20 cm
SSX4ME100G2-FI	14.5 kg	60 x 20 x 20 cm
SSX4ME150F3-I	16 kg	79 x 21 x 15 cm
SSX4ME150G2-FI	16.5 kg	60 x 20 x 20 cm
SSX4ME200G2-FI	18.5 kg	62 x 20 x 20 cm
SSX4ME0100G-I	14 kg	60 x 20 x 20 cm
SSX4ME0150G-I	16 kg	60 x 20 x 20 cm
SSX4ME0200G-I	18 kg	62 x 20 x 20 cm

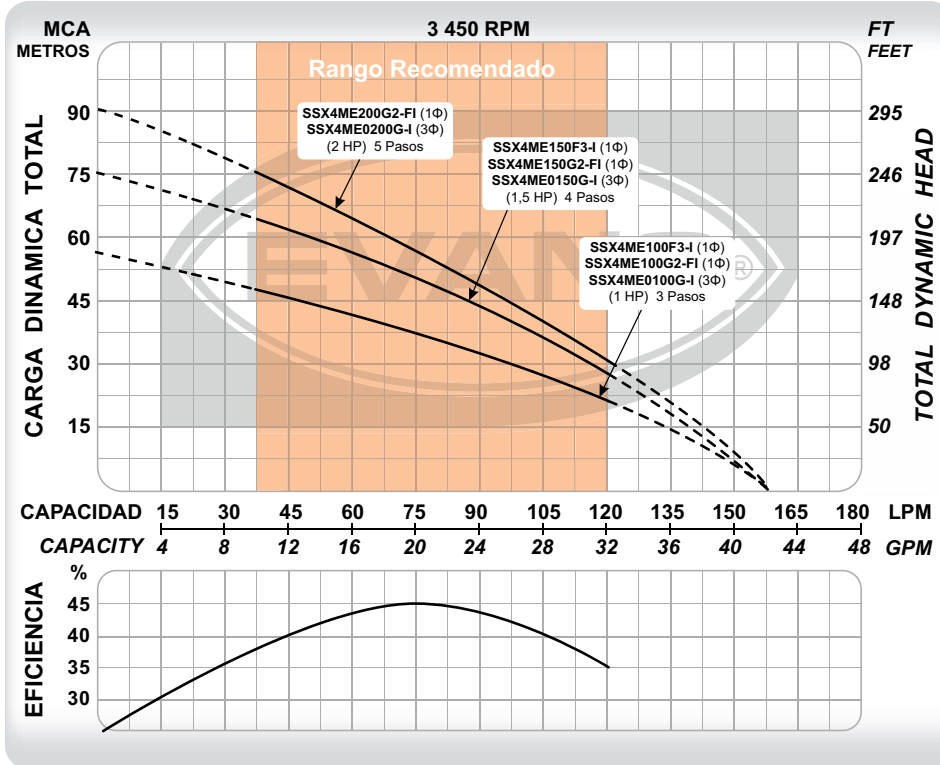
CÓDIGO	Ø DESCARGA	POTENCIA	VOLTAJE	CORRIENTE	ETAPAS	FLUJO MÁXIMO	PRESIÓN MÁXIMA	PUNTO DE MAYOR EFICIENCIA
SSX4ME100F3-I	1 ¼"	1 HP	115 V ~ 60Hz 1Φ	12.5 A	3	155 l/min	57 m	75 l/min a 38 m
SSX4ME100G2-FI	1 ¼"	1 HP	220 V ~ 60Hz 1Φ	6.1 A	3	155 l/min	57 m	75 l/min a 38 m
SSX4ME150F3-I	1 ¼"	1.5 HP	115 V ~ 60Hz 1Φ	15 A	4	155 l/min	75 m	75 l/min a 50 m
SSX4ME150G2-FI	1 ¼"	1.5 HP	220 V ~ 60Hz 1Φ	8.4 A	4	155 l/min	75 m	75 l/min a 50 m
SSX4ME200G2-FI	1 ¼"	2 HP	220 V ~ 60Hz 1Φ	10.6 A	5	155 l/min	91 m	75 l/min a 55 m
SSX4ME0100G-I	1 ¼"	1 HP	220 V ~ 60Hz 3Φ	4.5 A	3	155 l/min	57 m	75 l/min a 38 m
SSX4ME0150G-I	1 ¼"	1.5 HP	220 V ~ 60Hz 3Φ	6.2 A	4	155 l/min	75 m	75 l/min a 50 m
SSX4ME0200G-I	1 ¼"	2 HP	220 V ~ 60Hz 3Φ	8.2 A	5	155 l/min	91 m	75 l/min a 55 m

Disfruta la presión del agua



1
año
GARANTÍA



- Equipo ideal para la presurización de comercios ó pequeñas industrias.
- Excelente opción para instalarse en equipos multibomba con variadores de frecuencia.
- Succión inferior para el máximo aprovechamiento del volumen total de agua dentro de la cisterna.
- Impulsores fabricados en acero inoxidable 304.



DIAGRAMA DE INSTALACIÓN PARA PRESIÓN CONSTANTE

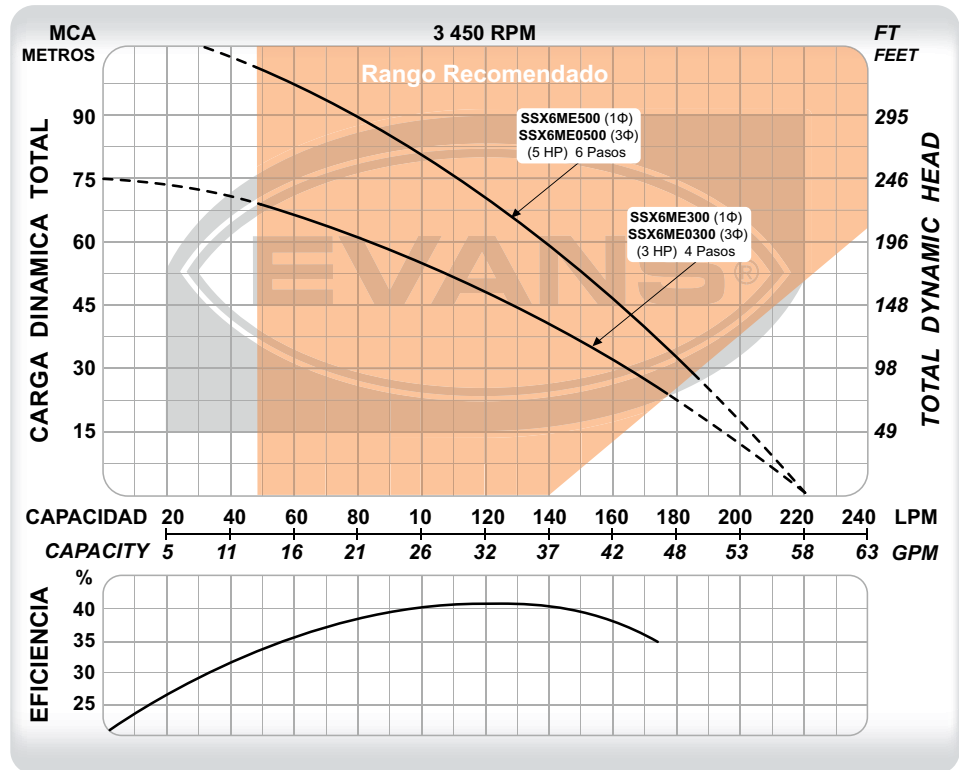

CÓDIGO	PESO	MEDIDAS LARGO x ANCHO x ALTO
SSX6ME300	27 kg	100 x 27 x 17 cm
SSX6ME500	30 kg	109 x 27 x 17 cm
SSX6ME0300	27 kg	100 x 27 x 17 cm
SSX6ME0500	30 kg	109 x 27 x 17 cm

CÓDIGO	Ø DESCARGA	POTENCIA	VOLTAJE	CORRIENTE	ETAPAS	FLUJO MÁXIMO	PRESIÓN MÁXIMA	PUNTO DE MAYOR EFICIENCIA
SSX6ME300	1 ½"	3 HP	220 V ~ 60Hz 1Φ	15.5 A	4	220 l/min	75 m	120 l/min a 48 m
SSX6ME500	1 ½"	5 HP	220 V ~ 60Hz 1Φ	24 A	6	220 l/min	105 m	120 l/min a 72 m
SSX6ME0300	1 ½"	3 HP	220 V ~ 60Hz 3Φ	9.8 A	4	220 l/min	75 m	120 l/min a 48 m
SSX6ME0500	1 ½"	5 HP	220 V ~ 60Hz 3Φ	14 A	6	220 l/min	105 m	120 l/min a 72 m

CARACTERÍSTICAS GENERALES DEL MOTOR SD4



CLASE 1H

El acoplamiento de los motores sumergibles EVANS® de 4" cumple los estándares de la Asociación Nacional de Manufactura Eléctrica (NEMA) y es compatible con las unidades de bombeo de diferentes marcas que tengan cumplimiento NEMA. Consulta a tu Asesor EVANS®.

No.	COMPONENTES
1	Protección inferior
2	Diafragma de compensación
3	Soporte inferior
4	Cubierta motor
5	Estator
6	Rotor
7	Glándula cable
8	Abrazadera cable
9	Cable
10	Cubierta anti arena
11	Soporte superior
12	O-ring
13	Sello mecánico
14	Balero superior
15	Balero inferior
16	Anillo base

MATERIALES DE MOTOR	
Material del cuerpo	AISI 304
Rotor / Flecha	AISI 316. Una sola pieza
Sello mecánico	Grafito /cerámica / NBR / AISI 304
Submersibilidad	120 m
Rodamientos	Cerámica / Buna-N
Aceite	Mineral blanco. SINOPEC #25
Acoplamiento	NEMA
Temperatura máx.	35°C
PH del agua	5.5 - 8.9

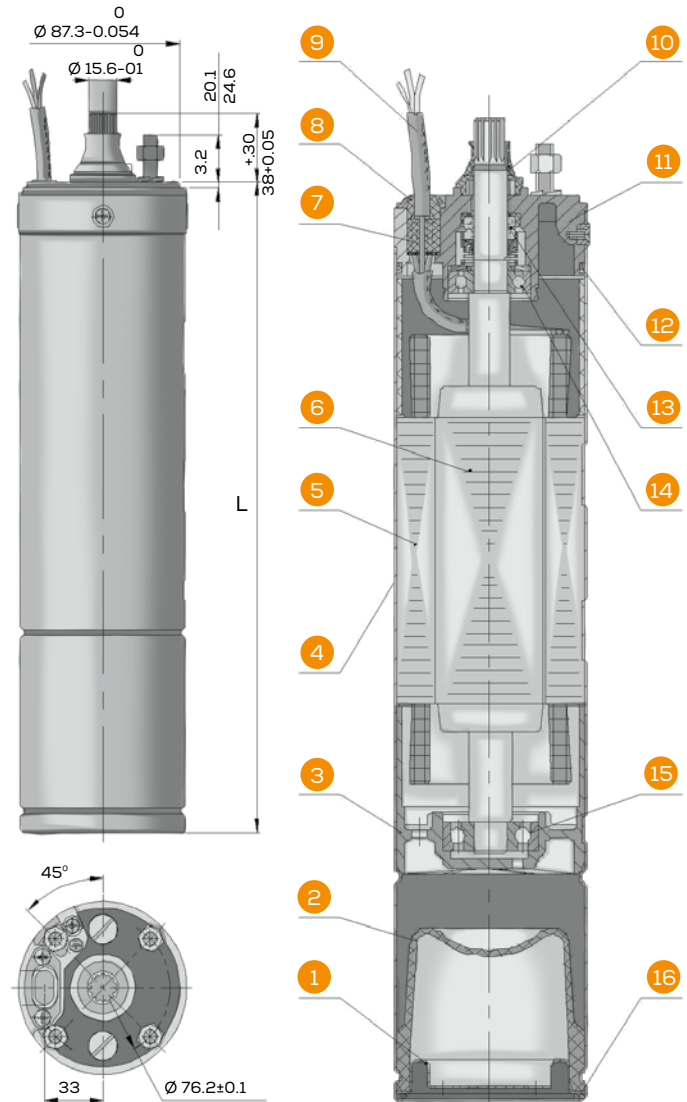

PESOS Y MEDIDAS								
CÓDIGO	POTENCIA (HP)	L (cm)	PESO (kg)	VOLTAJE	CORRIENTE NOMINAL (A)	FACTOR SERVICIO	CORRIENTE MÁX. (A)	EMPUJE AXIAL (N)
E24S050F3-P	1/2	35.8	8	110V ~ 60Hz 1Φ	6.8	1.6	10.9	1500
E24S050G3-P		7.8	220V ~ 60Hz 1Φ	3.7	6			
E24S0050G-P	1	40.8	7	220V ~ 60Hz 3Φ	2.1	1.4	3.4	
E24S100F3-P		10.2	110V ~ 60Hz 1Φ	11	15.5			
E24S100G3-P	10	40.3	10	220V ~ 60Hz 1Φ	5.5	1.3	7.6	
E24S0100G-P	9.4	44.8	9.4	220V ~ 60Hz 3Φ	3.9		5.5	
E24S150F3-P	1.5	43.3	11	110V ~ 60Hz 1Φ	14.4	1.3	18.9	2500
E24S150G3-P		10.8	220V ~ 60Hz 1Φ	7.2	9.4			
E24S0150G-P	2	46.8	10	220V ~ 60Hz 3Φ	5	1.25	6.4	
E24S200G3-P		12.6	220V ~ 60Hz 1Φ	9.6	12			
E24S0200G-P	3	47.5	11.7	220V ~ 60Hz 3Φ	6.5	1.15	8.2	
E24S300G3-P		14.8	220V ~ 60Hz 1Φ	13.6	15.6			
E24S0300G-P	5	53.5	14.3	220V ~ 60Hz 3Φ	9.5	1.15	10.9	
E24S500G3-P		21.8	220V ~ 60Hz 1Φ	22.5	25.9			
E24S0500G-P	7.5	66.4	27	220V ~ 60Hz 3Φ	15	1.15	17.3	
E24S0750G-P		27	220V ~ 60Hz 3Φ	22.6	25.9			
E24S1000G-P	10	90.3	33.3	220V ~ 60Hz 3Φ	31.5	1.15	36.2	
E24S1250G-P		35	220V ~ 60Hz 3Φ	39	44.9			

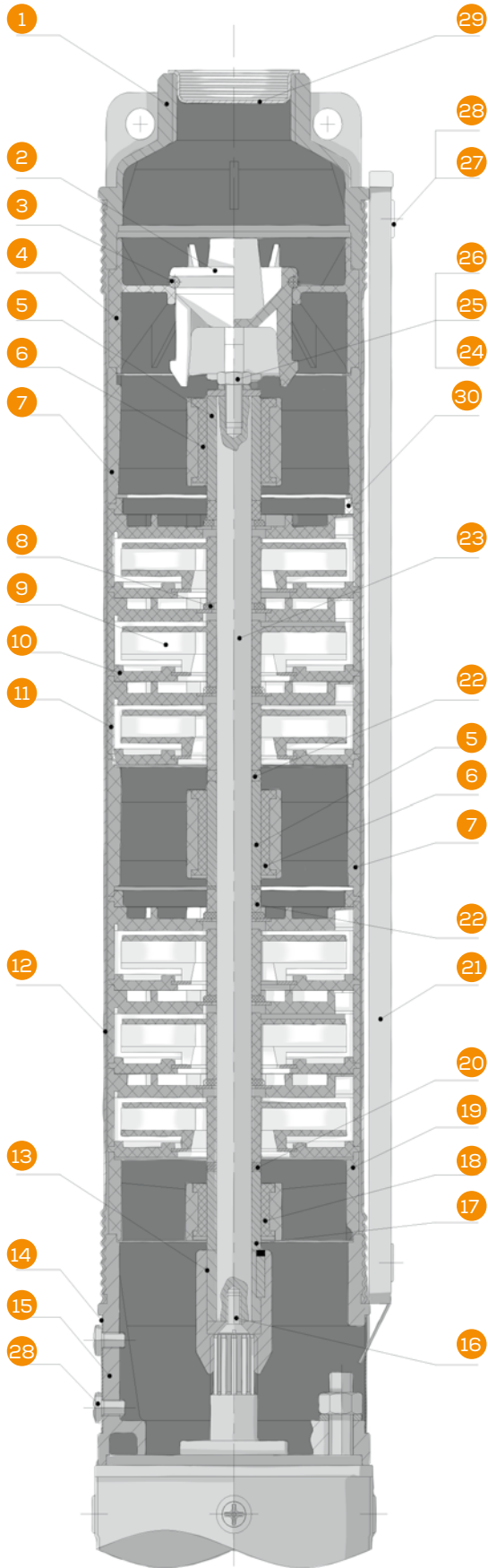

COMPONENTES

No.	PARTE
1	Descarga
2	Válvula check
3	O-ring
4	Soporte de válvula check
5	Buje del rodamiento
6	Rodamiento superior
7	Soporte de flecha superior
8	Arandela anti fricción
9	Impulsor
10	Cubierta del difusor
11	Difusor
12	Cuerpo de bomba
13	Acoplamiento
14	Filtro
15	Soporte de succión
16	Tornillo M5 x 8
17	Buje del rodamiento
18	Rodamiento inferior
19	Soporte de flecha inferior
20	Junta
21	Cubierta de cable
22	Distanciador
23	Flecha
24	Arandela M6
25	Arandela M6
26	Perno sujetador M6 x 16
27	Abrazadera de cubierta del cable
28	Tornillo M5 x 8
29	Cubierta
30	Anillo elástico de fijación

MATERIALES DE UNIDAD DE BOMBEO

Material del cuerpo	AISI 304
Descarga	AISI 304
Succión	AISI 304
Flecha de bomba	AISI 420
Cople	AISI 420
Protector de cable	AISI 304
Bushing superior e inferior	AISI 420
Soporte de válvula check	PC y fibra de vidrio
Impulsores	Noryl®
Difusores	PC y fibra de vidrio
Válvula check	POM
Rodamientos de bomba	Cerámica / Buna-N
Acoplamiento	NEMA
Máx. contenido de arena	15% ~ 150 g/m3
PH del agua	5.5 - 8.9

CARACTERÍSTICAS GENERALES DE UNIDAD DE BOMBEO DE 4" EN ACERO INOXIDABLE



COMPONENTES

No.	PARTE
1	Descarga
2	Rodamiento
3	Impulsor
4	Tuerca del separador
5	Separador de etapas
6	Difusor
7	Anillo de sujeción
8	Flecha
9	Retén
10	Rejilla de succión
11	Tornillo y tuerca
12	Cople
13	Guardacable

MATERIALES DE UNIDAD DE BOMBEO

Material del cuerpo	AISI 304
Descarga	AISI 304
Succión	AISI 304
Flecha de bomba	AISI 431
Cople	AISI 304
Protector de cable	AISI 304
Soporte de válvula check	AISI 304
Impulsores	AISI 304
Difusores	AISI 304
Válvula check	AISI 304
Rodamientos de bomba	Buna-N
Acoplamiento	NEMA
Máx. contenido de arena	5% ~ 50g/m ³
PH del agua	5.5 - 8.9

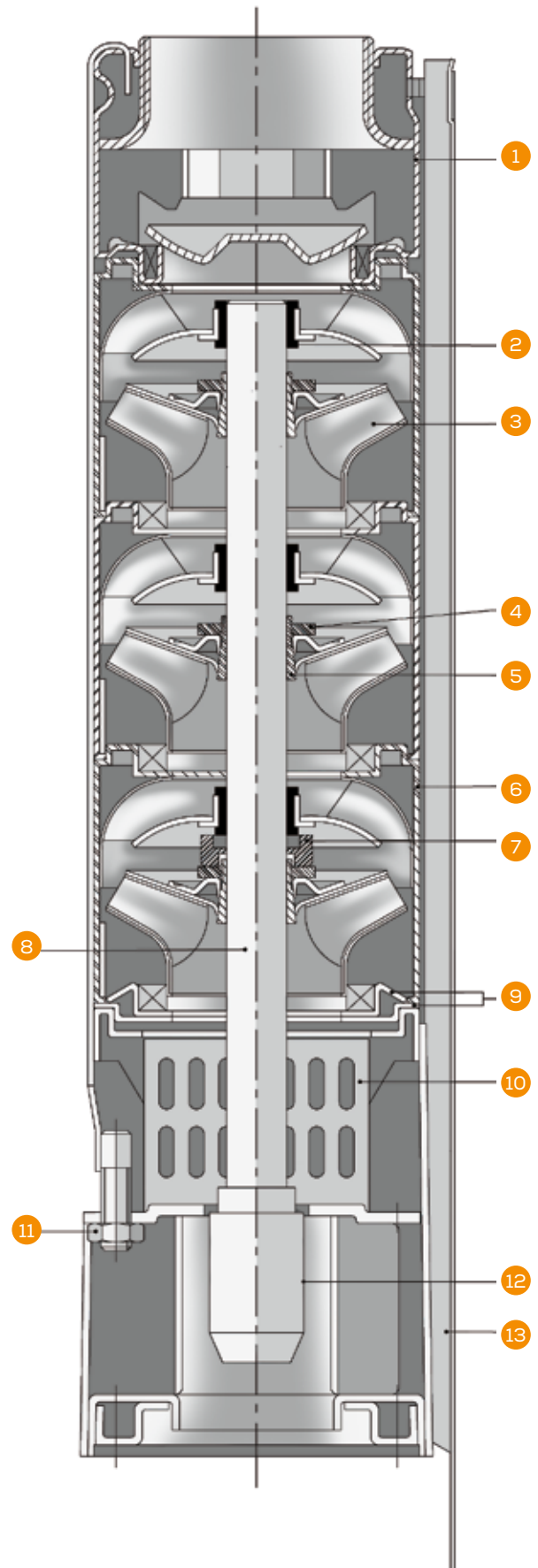



CAJAS DE CONTROL DE UN CAPACITOR PARA BOMBAS SUMERGIBLES

CÓDIGO	POTENCIA	VOLTAJE	CORRIENTE NOMINAL (A)	FACTOR SERVICIO	CORRIENTE MAX (A)	CAPACITOR
EMCCD.50F-P	1/2 HP	110 V ~ 60Hz 1Φ	6.8 A	1.6	10.9 A	60μF 250VAC
EMCCD.50G-P		220 V ~ 60Hz 1Φ	3.7 A		6 A	20μF 450VAC
EMCCD1.0F-P	1 HP	110 V ~ 60Hz 1Φ	11 A	1.4	15.5 A	100μF 250VAC
EMCCD1.0G-P		220 V ~ 60Hz 1Φ	5.5 A		7.6 A	30μF 450VAC
EMCCD1.5F-P	1.5 HP	110 V ~ 60Hz 1Φ	14.4 A	1.3	18.9 A	120μF 250VAC
EMCCD1.5G-P		220 V ~ 60Hz 1Φ	7.2 A		9.4 A	40μF 450VAC



CAJAS DE CONTROL DE DOBLE CAPACITOR PARA BOMBAS SUMERGIBLES

CÓDIGO	POTENCIA	VOLTAJE	CORRIENTE NOMINAL (A)	FACTOR SERVICIO	CORRIENTE MAX (A)	CAPACITOR DE ARRANQUE	CAPACITOR DE ARRANQUE
EMCCD.50F-P2	1/2 HP	110 V ~ 60Hz 1Φ	6.8 A	1.6	10.9 A	90μF 250VAC	60μF 250VAC
EMCCD.50G-P2		220 V ~ 60Hz 1Φ	3.7 A		6 A	30μF 250VAC	20μF 450VAC
EMCCD1.0F-P2	1 HP	110 V ~ 60Hz 1Φ	11 A	1.4	15.5 A	150μF 250VAC	100μF 250VAC
EMCCD1.0G-P2		220 V ~ 60Hz 1Φ	5.5 A		7.6 A	50μF 250VAC	30μF 450VAC
EMCCD1.5F-P2	1.5 HP	110 V ~ 60Hz 1Φ	14.4 A	1.3	18.9 A	180μF 250VAC	120μF 250VAC
EMCCD1.5G-P2		220 V ~ 60Hz 1Φ	7.2 A		9.4 A	70μF 250VAC	40μF 450VAC
EMCCD2.0G-P2	2 HP	220 V ~ 60Hz 1Φ	9.6 A	1.25	12 A	100μF 250VAC	50μF 450VAC
EMCCD3.0G-P2	3 HP	220 V ~ 60Hz 1Φ	13.6	1.15	15.6	50μF 450VAC	60μF 450VAC
EMCCD5.0G-P2	5 HP	220 V ~ 60Hz 1Φ	22.5 A		25.9 A	160μF 250VAC	80μF 450VAC

Las bombas sumergibles de lapicero sirven para impulsar agua limpia a temperatura ambiente con gran presión, gracias a su sistema de múltiples etapas.

Todas las bombas Evans® se someten a una detenida verificación, para lograr la satisfacción total del cliente.

- IDEAL PARA EXTRACCIÓN DE AGUA DE POZOS PROFUNDOS.
- SUMINISTRO DE AGUA LIMPIA EN GRANJAS, RIEGO AGRÍCOLA, FÁBRICAS, MINAS, COMPLEJOS RESIDENCIALES, INDUSTRIA, ETC.
- RESISTENTES Y ANTI CORROSIVAS POR SUS MATERIALES EN ACERO INOXIDABLE.

CONSIDERACIONES PARA LA SELECCIÓN DE TU EQUIPO

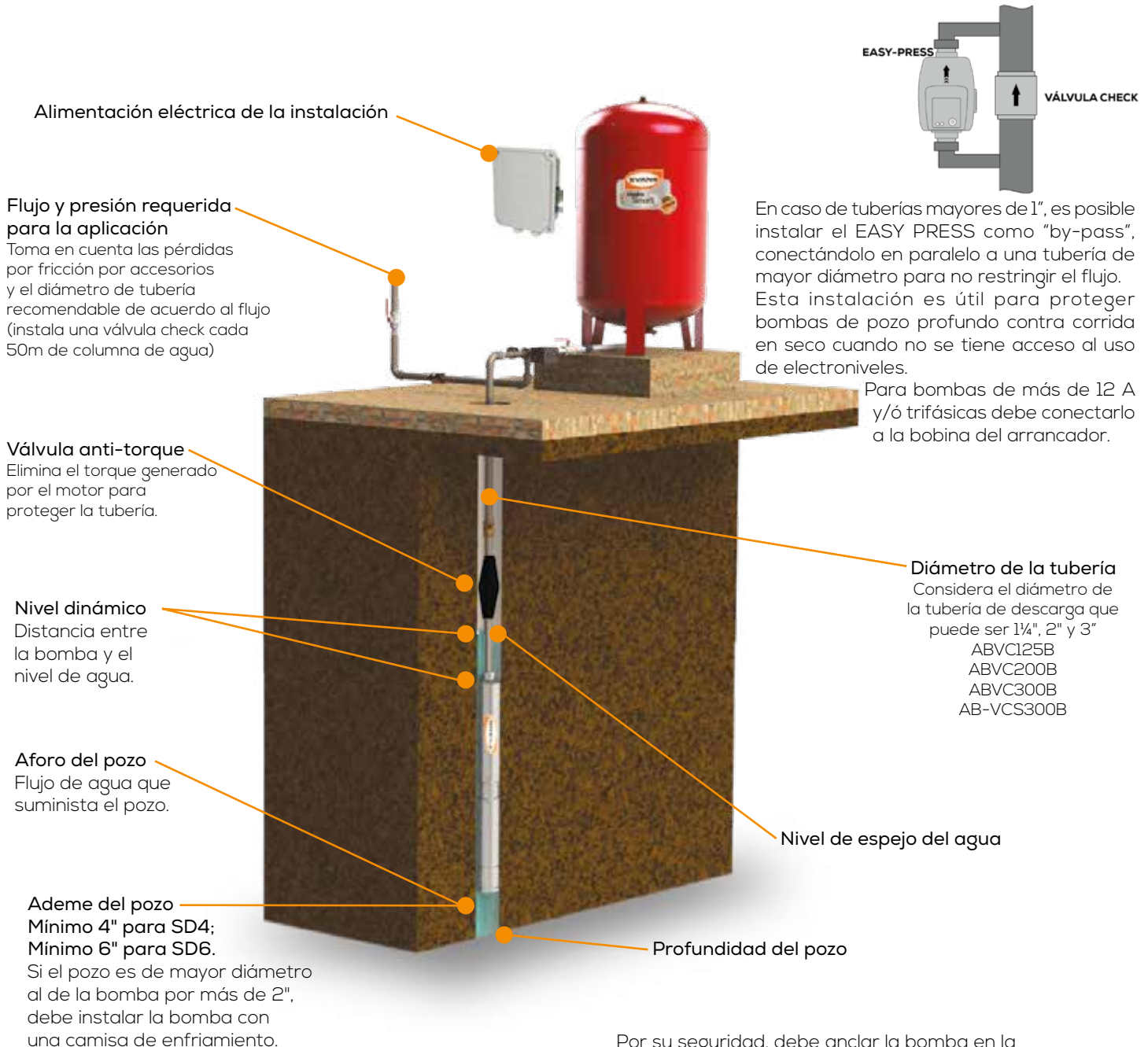

Por su seguridad, debe anclar la bomba en la superficie, sujetándola de los extremos de la descarga para evitar que caiga al pozo profundo.



- La más resistente a la arena en su categoría.
- Impulsores tipo flotantes fabricados en Noryl®.
- Difusores fabricados en policarbonato.
- Descarga y cople en acero inoxidable extra resistentes.
- Válvula check integrada.

LOS EQUIPOS MONOFÁSICOS INCLUYEN CAJA DE CONTROL METÁLICA HERMÉTICAMENTE SELLADA.

DIAGRAMA DE INSTALACIÓN PARA HIDRONEUMÁTICO

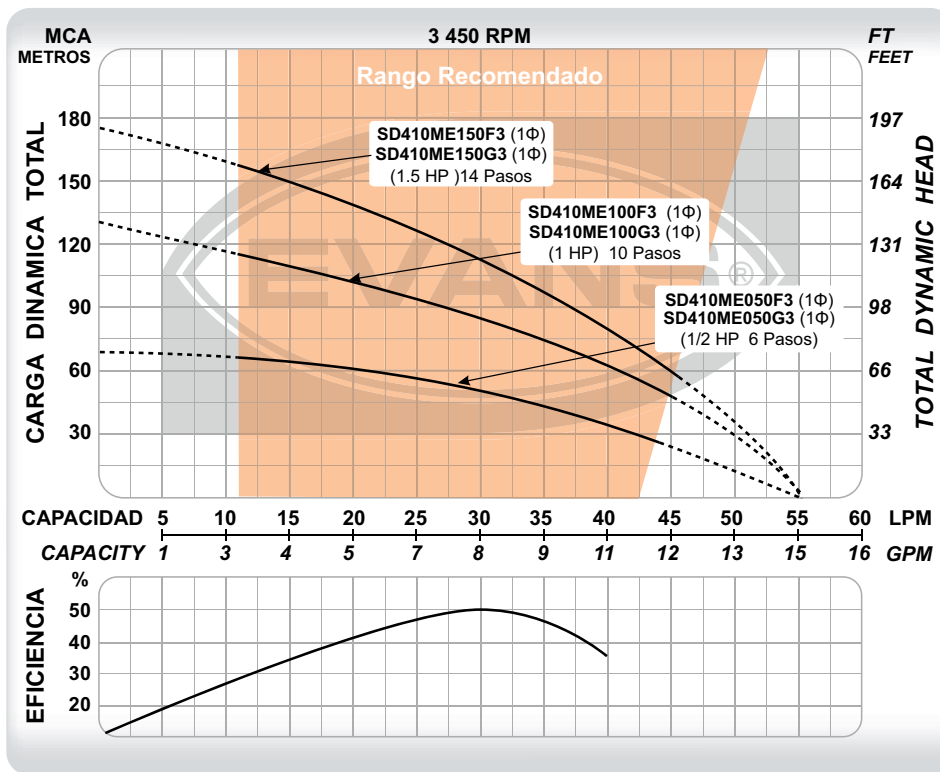

CÓDIGO PESO MEDIDAS

LARGO x ANCHO x ALTO

CÓDIGO	PESO	MEDIDAS
SD410ME050F3	12 kg	75 x 12 x 12 cm
SD410ME050G3	12 kg	75 x 12 x 12 cm
SD410ME100F3	14 kg	88 x 12 x 12 cm
SD410ME100G3	14 kg	88 x 12 x 12 cm
SD410ME150F3	17 kg	100 x 12 x 12 cm
SD410ME150G3	17 kg	100 x 12 x 12 cm

CÓDIGO	Ø DESCARGA	POTENCIA	VOLTAJE	CORRIENTE	ETAPAS	FLUJO MÁXIMO	PRESIÓN MÁXIMA	PUNTO DE MAYOR EFICIENCIA
SD410ME050F3	1 ¼"	1/2 HP	110 V ~ 60Hz 1Φ	10.9 A	6	55 l/min	74 m	30 l/min a 50 m
SD410ME050G3	1 ¼"	1/2 HP	220 V ~ 60Hz 1Φ	6 A	6	55 l/min	74 m	30 l/min a 50 m
SD410ME100F3	1 ¼"	1 HP	110 V ~ 60Hz 1Φ	15.5 A	10	55 l/min	125 m	30 l/min a 83 m
SD410ME100G3	1 ¼"	1 HP	220 V ~ 60Hz 1Φ	7.6 A	10	55 l/min	125 m	30 l/min a 83 m
SD410ME150F3	1 ¼"	1.5 HP	110 V ~ 60Hz 1Φ	18.9 A	14	55 l/min	176 m	30 l/min a 118 m
SD410ME150G3	1 ¼"	1.5 HP	220 V ~ 60Hz 1Φ	9.4 A	14	55 l/min	176 m	30 l/min a 118 m

BOMBA SUMERGIBLE 4" | 8 GPM

Desempeño de altura

CLASE 1H



1
año
GARANTÍA



- La más resistente a la arena en su categoría.
- Impulsores tipo flotantes fabricados en Noryl®.
- Difusores fabricados en policarbonato.
- Descarga y cople en acero inoxidable extra resistentes.
- Válvula check integrada.



DIAGRAMA DE INSTALACIÓN PARA HIDRONEUMÁTICO



CÓDIGO	PESO	MEDIDAS LARGO x ANCHO x ALTO
SD410ME0050G	11.4 kg	79 x 12 x 12 cm
SD410ME0100G	14 kg	90 x 12 x 12 cm
SD410ME0150G	15.5 kg	100 x 12 x 12 cm

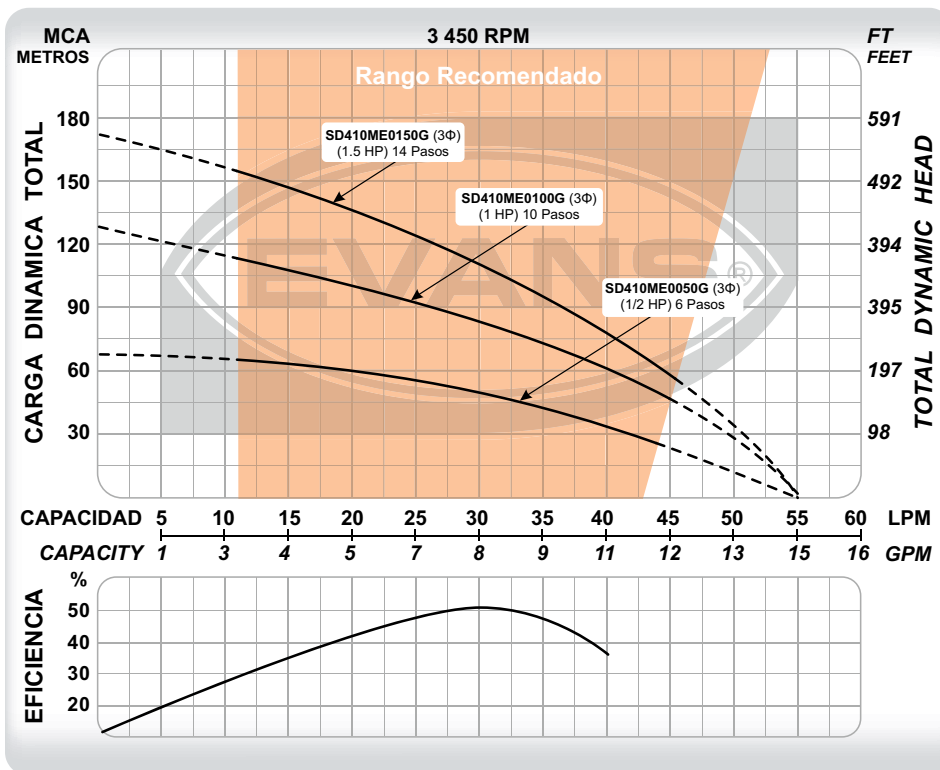

CÓDIGO	Ø DESCARGA	POTENCIA	VOLTAJE	CORRIENTE	ETAPAS	FLUJO MÁXIMO	PRESIÓN MÁXIMA	PUNTO DE MAYOR EFICIENCIA
SD410ME0050G	1 ¼"	1/2 HP	220 V ~ 60Hz 3Φ	3.4 A	6	55 l/min	74 m	30 l/min a 50 m
SD410ME0100G	1 ¼"	1 HP	220 V ~ 60Hz 3Φ	5.5 A	10	55 l/min	125 m	30 l/min a 83 m
SD410ME0150G	1 ¼"	1.5 HP	220 V ~ 60Hz 3Φ	6.4 A	14	55 l/min	176 m	30 l/min a 118 m



- La mejor eficiencia y desempeño en su categoría.
- Impulsores y difusores fabricados en acero inoxidable 304.
- Válvula check integrada.



LOS EQUIPOS MONOFÁSICOS INCLUYEN CAJA DE CONTROL METÁLICA HERMÉTICAMENTE SELLADA.

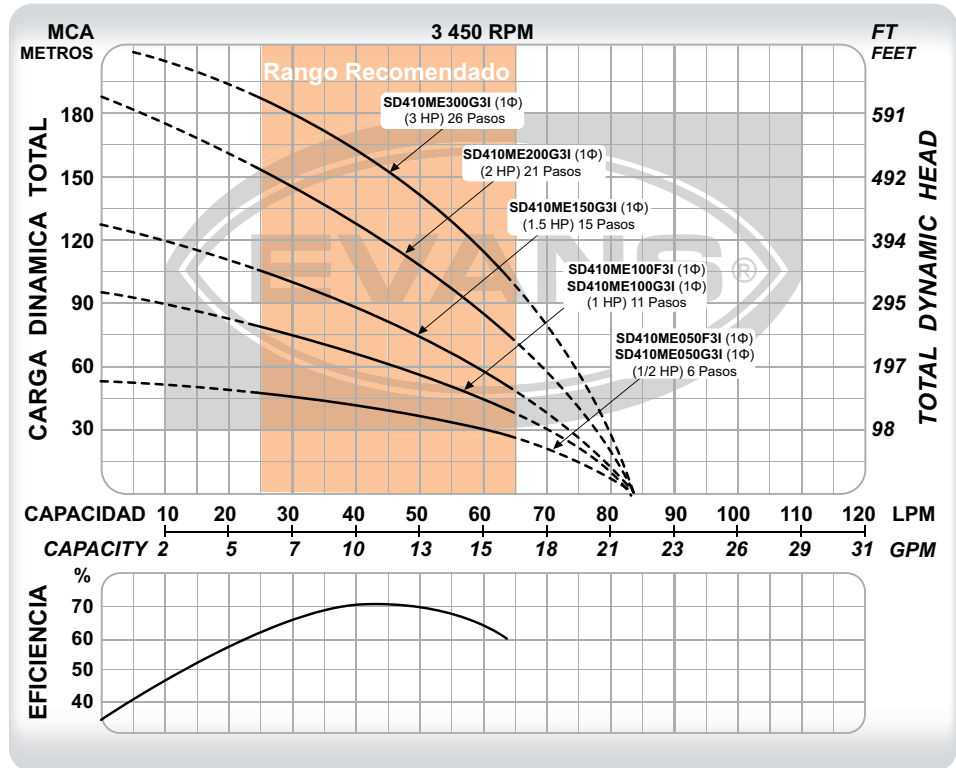

CÓDIGO	PESO	MEDIDAS LARGO x ANCHO x ALTO
SD410ME050F31	11.5 kg	79 x 12 x 12 cm
SD410ME050G31	11.5 kg	79 x 12 x 12 cm
SD410ME100F31	15 kg	94 x 12 x 12 cm
SD410ME100G31	14.5 kg	94 x 12 x 12 cm
SD410ME150G31	16.5 kg	105 x 12 x 12 cm
SD410ME200G31	19.5 kg	122 x 12 x 12 cm
SD410ME300G31	23.5 kg	137 x 12 x 12 cm

CÓDIGO	Ø DESCARGA	POTENCIA	VOLTAJE	CORRIENTE	ETAPAS	FLUJO MÁXIMO	PRESIÓN MÁXIMA	PUNTO DE MAYOR EFICIENCIA
SD410ME050F31	1 ¼"	1/2 HP	110 V ~ 60Hz 1Φ	10.9 A	6	85 l/min	55 m	45 l/min a 37 m
SD410ME050G31	1 ¼"	1/2 HP	220 V ~ 60Hz 1Φ	6 A	6	85 l/min	55 m	45 l/min a 37 m
SD410ME100F31	1 ¼"	1 HP	110 V ~ 60Hz 1Φ	15.5 A	11	85 l/min	97 m	45 l/min a 65 m
SD410ME100G31	1 ¼"	1 HP	220 V ~ 60Hz 1Φ	7.6 A	11	85 l/min	97 m	45 l/min a 65 m
SD410ME150G31	1 ¼"	1.5 HP	220 V ~ 60Hz 1Φ	9.4 A	15	85 l/min	130 m	45 l/min a 84 m
SD410ME200G31	1 ¼"	2 HP	220 V ~ 60Hz 1Φ	12 A	21	85 l/min	187 m	45 l/min a 121 m
SD410ME300G31	1 ¼"	3 HP	220 V ~ 60Hz 1Φ	15.6 A	26	85 l/min	231 m	45 l/min a 154 m

BOMBA SUMERGIBLE INOXIDABLE 4" | 10 GPM

Desempeño de altura

CLASE 1H



1
año
GARANTÍA



- La mejor eficiencia y desempeño en su categoría.
- Impulsores y difusores fabricados en acero inoxidable 304.
- Válvula check integrada.

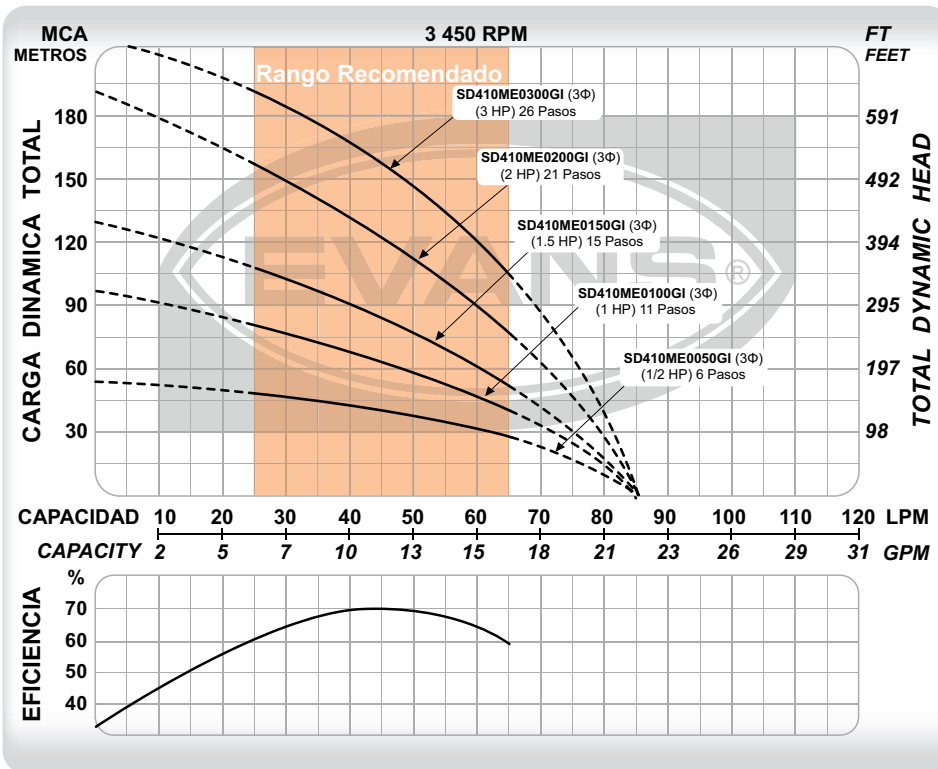

CÓDIGO	PESO	MEDIDAS LARGO x ANCHO x ALTO
SD410ME0050GI	10.5 kg	84 x 12 x 12 cm
SD410ME0100GI	14 kg	98 x 12 x 12 cm
SD410ME0150GI	16 kg	109 x 12 x 12 cm
SD410ME0200GI	19 kg	122 x 12 x 12 cm
SD410ME0300GI	23 kg	139 x 12 x 12 cm

CÓDIGO	Ø DESCARGA	POTENCIA	VOLTAJE	CORRIENTE	ETAPAS	FLUJO MÁXIMO	PRESIÓN MÁXIMA	PUNTO DE MAYOR EFICIENCIA
SD410ME0050GI	1 ¼"	1/2 HP	220 V ~ 60Hz 3Φ	3.4 A	6	85 l/min	55 m	45 l/min a 37 m
SD410ME0100GI	1 ¼"	1 HP	220 V ~ 60Hz 3Φ	5.5 A	11	85 l/min	97 m	45 l/min a 65 m
SD410ME0150GI	1 ¼"	1.5 HP	220 V ~ 60Hz 3Φ	6.4 A	15	85 l/min	130 m	45 l/min a 84 m
SD410ME0200GI	1 ¼"	2 HP	220 V ~ 60Hz 3Φ	8.2 A	21	85 l/min	187 m	45 l/min a 121 m
SD410ME0300GI	1 ¼"	3 HP	220 V ~ 60Hz 3Φ	10.9 A	26	85 l/min	231 m	45 l/min a 154 m

Desempeño de altura



- La más resistente a la arena en su categoría.
- Impulsores tipo flotantes fabricados en Noryl®.
- Difusores fabricados en policarbonato.
- Descarga y cople en acero inoxidable extra resistentes.
- Válvula check integrada.

LOS EQUIPOS MONOFÁSICOS INCLUYEN CAJA DE CONTROL METÁLICA HERMÉTICAMENTE SELLADA.

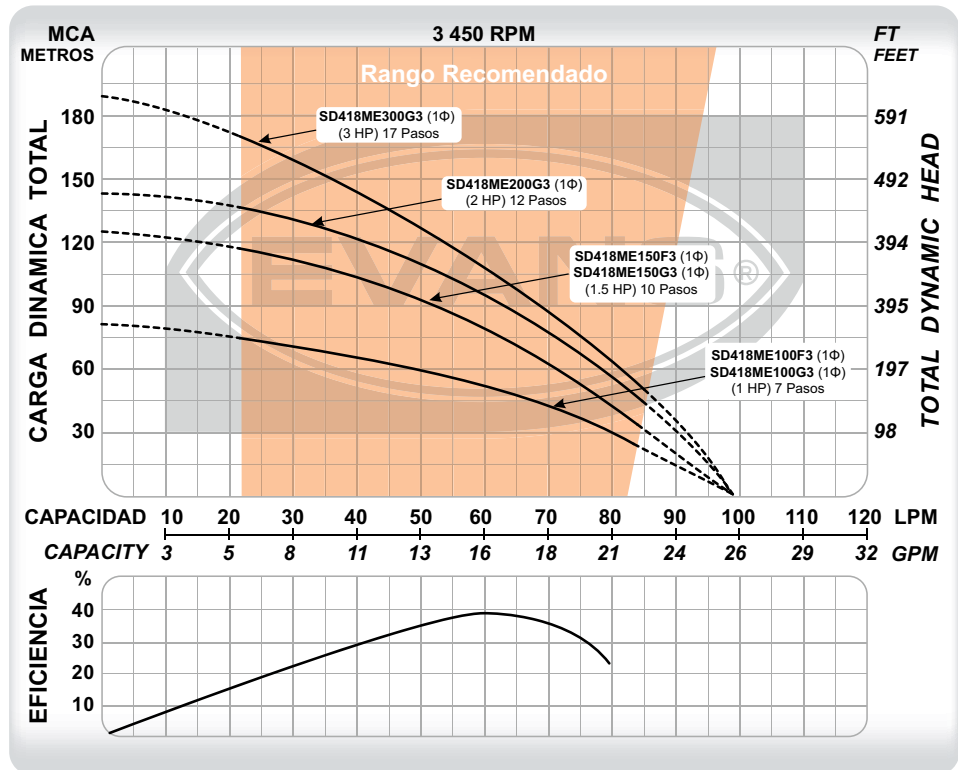

CÓDIGO	PESO	MEDIDAS LARGO x ANCHO x ALTO
SD418ME100F3	15 kg	85 x 12 x 12 cm
SD418ME100G3	15 kg	85 x 12 x 12 cm
SD418ME150F3	16 kg	95 x 12 x 12 cm
SD418ME150G3	16 kg	95 x 12 x 12 cm
SD418ME200G3	15.5 kg	110 x 12 x 12 cm
SD418ME300G3	22 kg	130 x 12 x 12 cm

CÓDIGO	Ø DESCARGA	POTENCIA	VOLTAJE	CORRIENTE	ETAPAS	FLUJO MÁXIMO	PRESIÓN MÁXIMA	PUNTO DE MAYOR EFICIENCIA
SD418ME100F3	1 ¼"	1 HP	110 V ~ 60Hz 1Φ	15.5 A	7	98 l/min	81 m	60 l/min a 53 m
SD418ME100G3	1 ¼"	1 HP	220 V ~ 60Hz 1Φ	7.6 A	7	98 l/min	81 m	60 l/min a 53 m
SD418ME150F3	1 ¼"	1.5 HP	110 V ~ 60Hz 1Φ	18.9 A	10	98 l/min	122 m	60 l/min a 80 m
SD418ME150G3	1 ¼"	1.5 HP	220 V ~ 60Hz 1Φ	9.4 A	10	98 l/min	122 m	60 l/min a 80 m
SD418ME200G3	1 ¼"	2 HP	220 V ~ 60Hz 1Φ	12 A	12	98 l/min	145 m	60 l/min a 95 m
SD418ME300G3	1 ¼"	3 HP	220 V ~ 60Hz 1Φ	15.6 A	17	98 l/min	190 m	60 l/min a 105 m

BOMBA SUMERGIBLE 4" | 16 GPM

Desempeño de altura



CLASE 1H

1
año
GARANTÍA



- La más resistente a la arena en su categoría.
- Impulsores tipo flotantes fabricados en Noryl®.
- Difusores fabricados en policarbonato.
- Descarga y cople en acero inoxidable extra resistentes.
- Válvula check integrada.

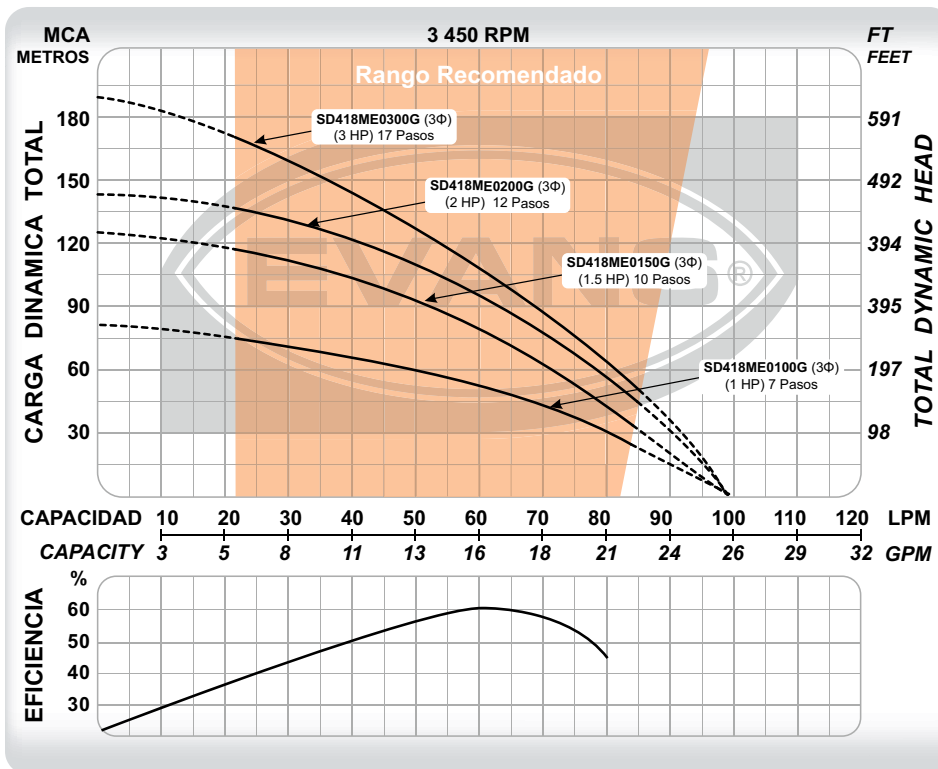

CÓDIGO	PESO	MEDIDAS LARGO x ANCHO x ALTO
SD418ME0100G	14 kg	85 x 12 x 12 cm
SD418ME0150G	16 kg	95 x 12 x 12 cm
SD418ME0200G	18 kg	110 x 12 x 12 cm
SD418ME0300G	21 kg	130 x 12 x 12 cm

CÓDIGO	Ø DESCARGA	POTENCIA	VOLTAJE	CORRIENTE	ETAPAS	FLUJO MÁXIMO	PRESIÓN MÁXIMA	PUNTO DE MAYOR EFICIENCIA
SD418ME0100G	1 ¼"	1 HP	220 V ~ 60Hz 3Φ	5.5 A	7	98 l/min	81 m	60 l/min a 53 m
SD418ME0150G	1 ¼"	1.5 HP	220 V ~ 60Hz 3Φ	6.4 A	10	98 l/min	122 m	60 l/min a 80 m
SD418ME0200G	1 ¼"	2 HP	220 V ~ 60Hz 3Φ	8.2 A	12	98 l/min	145 m	60 l/min a 95 m
SD418ME0300G	1 ¼"	3 HP	220 V ~ 60Hz 3Φ	10.7 A	17	98 l/min	190 m	60 l/min a 105 m



CLASE IH

BOMBA SUMERGIBLE INOXIDABLE 4" | 18 GPM

Desempeño de altura



1
año
GARANTÍA



- La mejor eficiencia y desempeño en su categoría.
- Impulsores y difusores fabricados en acero inoxidable 304.
- Válvula check integrada.

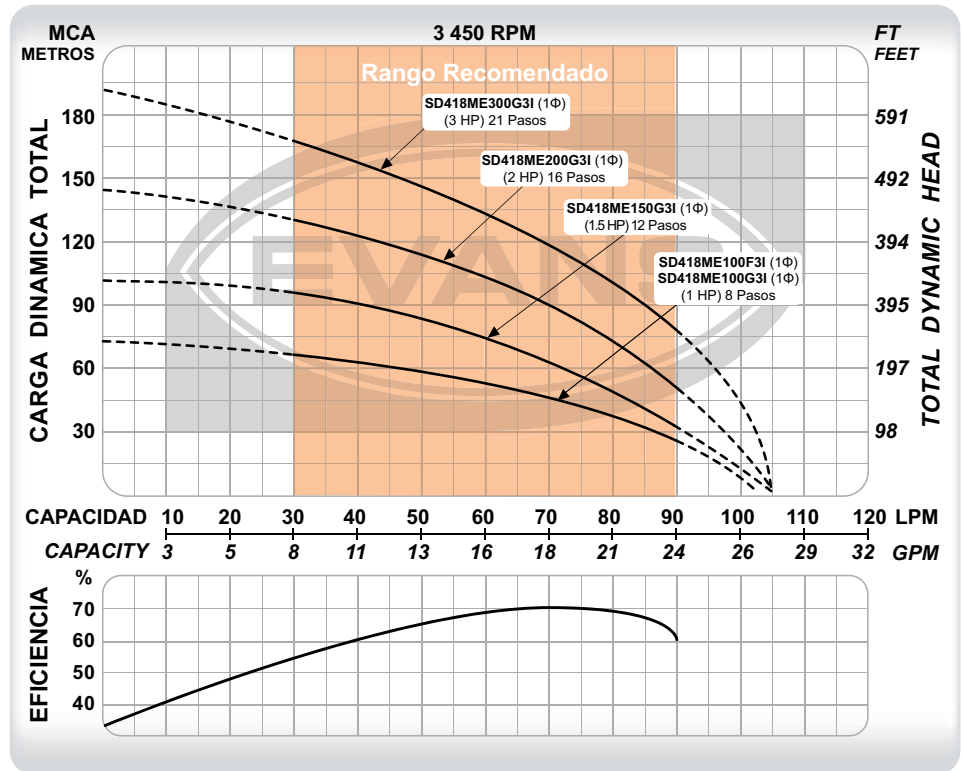

CÓDIGO	PESO	MEDIDAS LARGO x ANCHO x ALTO
SD418ME100F3I	14 kg	88 x 12 x 12 cm
SD418ME100G3I	14 kg	88 x 12 x 12 cm
SD418ME150G3I	16 kg	99 x 12 x 12 cm
SD418ME200G3I	18.5 kg	112 x 12 x 12 cm
SD418ME300G3I	22 kg	127 x 12 x 12 cm

CÓDIGO	Ø DESCARGA	POTENCIA	VOLTAJE	CORRIENTE	ETAPAS	FLUJO MÁXIMO	PRESIÓN MÁXIMA	PUNTO DE MAYOR EFICIENCIA
SD418ME100F3I	1 ¼"	1 HP	110 V ~ 60Hz 1Φ	15.5 A	8	105 l/min	73 m	70 l/min a 45 m
SD418ME100G3I	1 ¼"	1 HP	220 V ~ 60Hz 1Φ	7.6 A	8	105 l/min	73 m	70 l/min a 45 m
SD418ME150G3I	1 ¼"	1.5 HP	220 V ~ 60Hz 1Φ	9.4 A	12	105 l/min	105 m	70 l/min a 62 m
SD418ME200G3I	1 ¼"	2 HP	220 V ~ 60Hz 1Φ	12 A	16	105 l/min	146 m	70 l/min a 90 m
SD418ME300G3I	1 ¼"	3 HP	220 V ~ 60Hz 1Φ	15.6 A	21	105 l/min	190 m	70 l/min a 119 m

BOMBA SUMERGIBLE INOXIDABLE 4" | 18 GPM

Desempeño de altura



CLASE 1H

1 año GARANTÍA



- La mejor eficiencia y desempeño en su categoría.
- Impulsores y difusores fabricados en acero inoxidable 304.
- Válvula check integrada.

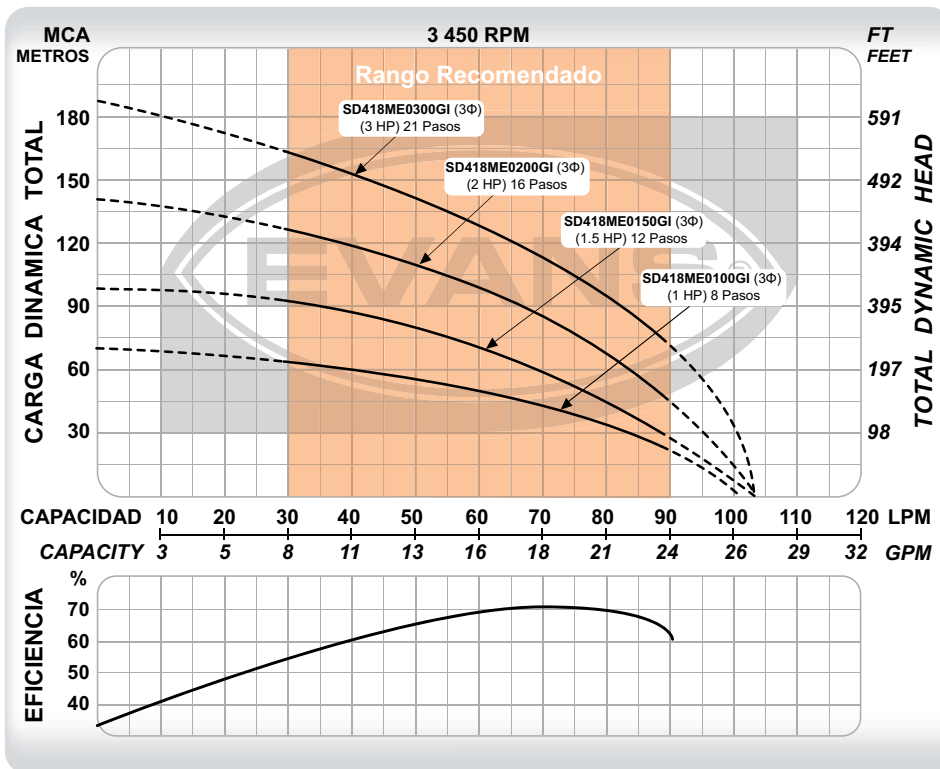

CÓDIGO	PESO	MEDIDAS LARGO x ANCHO x ALTO
SD418ME0100GI	13.5 kg	95 x 12 x 12 cm
SD418ME0150GI	16 kg	102 x 12 x 12 cm
SD418ME0200GI	18.5 kg	112 x 12 x 12 cm
SD418ME0300GI	21.5 kg	126 x 12 x 12 cm

CÓDIGO	Ø DESCARGA	POTENCIA	VOLTAJE	CORRIENTE	ETAPAS	FLUJO MÁXIMO	PRESIÓN MÁXIMA	PUNTO DE MAYOR EFICIENCIA
SD418ME0100GI	1 ¼"	1 HP	220 V ~ 60Hz 3Φ	5.5 A	8	105 l/min	73 m	70 l/min a 45 m
SD418ME0150GI	1 ¼"	1.5 HP	220 V ~ 60Hz 3Φ	6.4 A	12	105 l/min	105 m	70 l/min a 62 m
SD418ME0200GI	1 ¼"	2 HP	220 V ~ 60Hz 3Φ	8.2 A	16	105 l/min	146 m	70 l/min a 90 m
SD418ME0300GI	1 ¼"	3 HP	220 V ~ 60Hz 3Φ	10.9 A	21	105 l/min	190 m	70 l/min a 119 m



CLASE 1H

BOMBA SUMERGIBLE INOXIDABLE 4" | 18 GPM

Desempeño de altura



1
año
GARANTÍA



- La mejor eficiencia y desempeño en su categoría.
- Impulsores y difusores fabricados en acero inoxidable 304.
- Válvula check integrada.

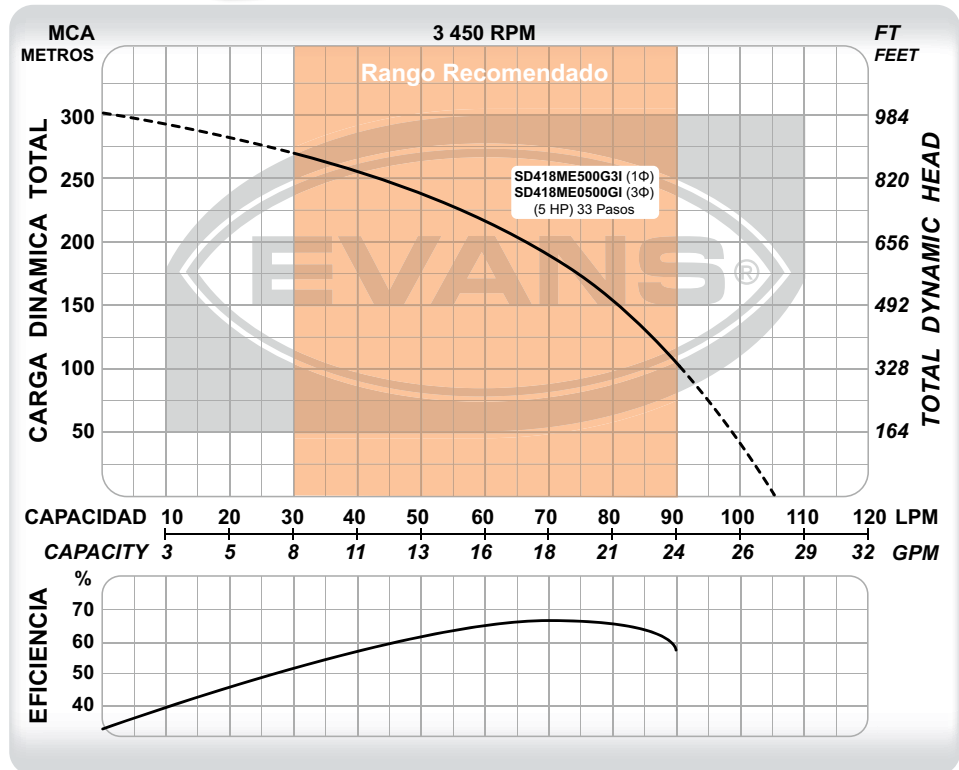

CÓDIGO	PESO	MEDIDAS
		LARGO x ANCHO x ALTO
SD418ME500G3I	32.5 kg	166 x 26 x 33 cm
SD418ME0500GI	33.5 kg	166 x 26 x 33 cm

CÓDIGO	Ø DESCARGA	POTENCIA	VOLTAJE	CORRIENTE	ETAPAS	FLUJO MÁXIMO	PRESIÓN MÁXIMA	PUNTO DE MAYOR EFICIENCIA
SD418ME500G3I	1 ¼"	5 HP	220 V ~ 60Hz 1Φ	25.9 A	33	105 l/min	300 m	70 l/min a 188 m
SD418ME0500GI	1 ¼"	5 HP	220 V ~ 60Hz 3Φ	17.3 A	33	105 l/min	300 m	70 l/min a 188 m

BOMBA SUMERGIBLE 4" | 25 GPM

Desempeño de altura

CLASE 1H



1
año
GARANTÍA



- La más resistente a la arena en su categoría.
- Impulsores tipo flotantes fabricados en Noryl®.
- Difusores fabricados en policarbonato.
- Descarga y cople en acero inoxidable extra resistentes.
- Válvula check integrada.



LOS EQUIPOS MONOFÁSICOS INCLUYEN CAJA DE CONTROL METÁLICA HERMÉTICAMENTE SELLADA.

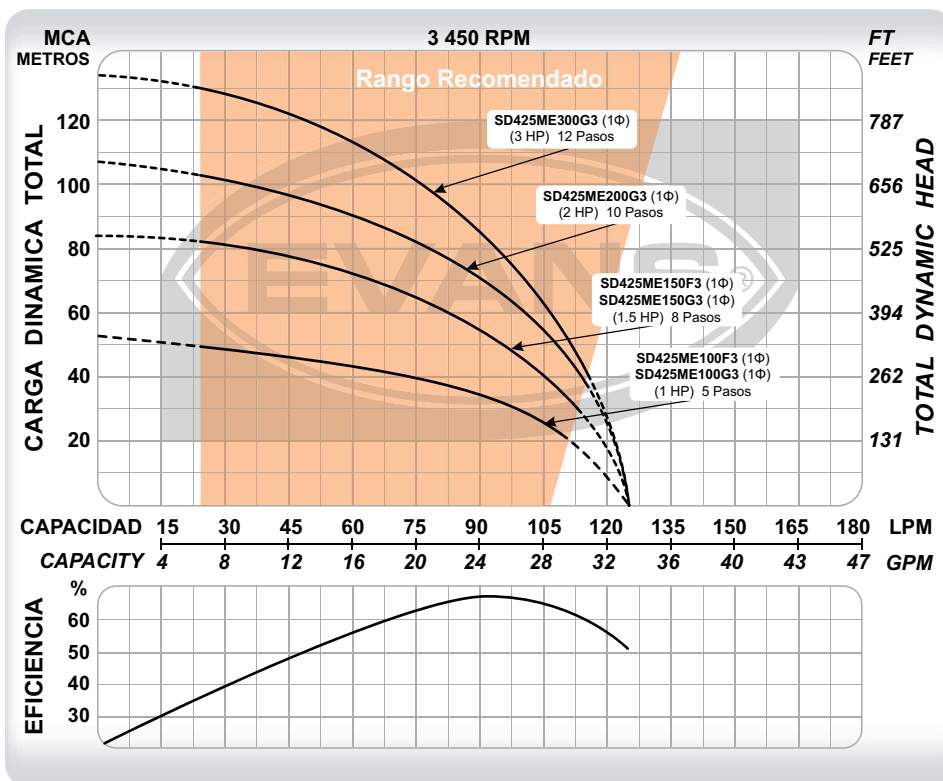

CÓDIGO	PESO	MEDIDAS LARGO x ANCHO x ALTO
SD425ME100F3	14 kg	85 x 12 x 12 cm
SD425ME100G3	14 kg	85 x 12 x 12 cm
SD425ME150F3	16 kg	95 x 12 x 12 cm
SD425ME150G3	16 kg	95 x 12 x 12 cm
SD425ME200G3	18 kg	110 x 12 x 12 cm
SD425ME300G3	20 kg	115 x 12 x 12 cm

CÓDIGO	Ø DESCARGA	POTENCIA	VOLTAJE	CORRIENTE	ETAPAS	FLUJO MÁXIMO	PRESIÓN MÁXIMA	PUNTO DE MAYOR EFICIENCIA
SD425ME100F3	2"	1 HP	110 V ~ 60Hz 1Φ	15.5 A	5	125 l/min	52 m	90 l/min a 32 m
SD425ME100G3	2"	1 HP	220 V ~ 60Hz 1Φ	7.6 A	5	125 l/min	52 m	90 l/min a 32 m
SD425ME150F3	2"	1.5 HP	110 V ~ 60Hz 1Φ	18.9 A	8	125 l/min	83 m	90 l/min a 55 m
SD425ME150G3	2"	1.5 HP	220 V ~ 60Hz 1Φ	9.4 A	8	125 l/min	83 m	90 l/min a 55 m
SD425ME200G3	2"	2 HP	220 V ~ 60Hz 1Φ	12 A	10	125 l/min	109 m	90 l/min a 71 m
SD425ME300G3	2"	3 HP	220 V ~ 60Hz 1Φ	15.6 A	12	125 l/min	132 m	90 l/min a 85 m



CLASE 1H

BOMBA SUMERGIBLE 4" | 25 GPM

Desempeño de altura



1
año
GARANTÍA

- La más resistente a la arena en su categoría.
- Impulsores tipo flotantes fabricados en Noryl®.
- Difusores fabricados en policarbonato.
- Descarga y cople en acero inoxidable extra resistentes.
- Válvula check integrada.

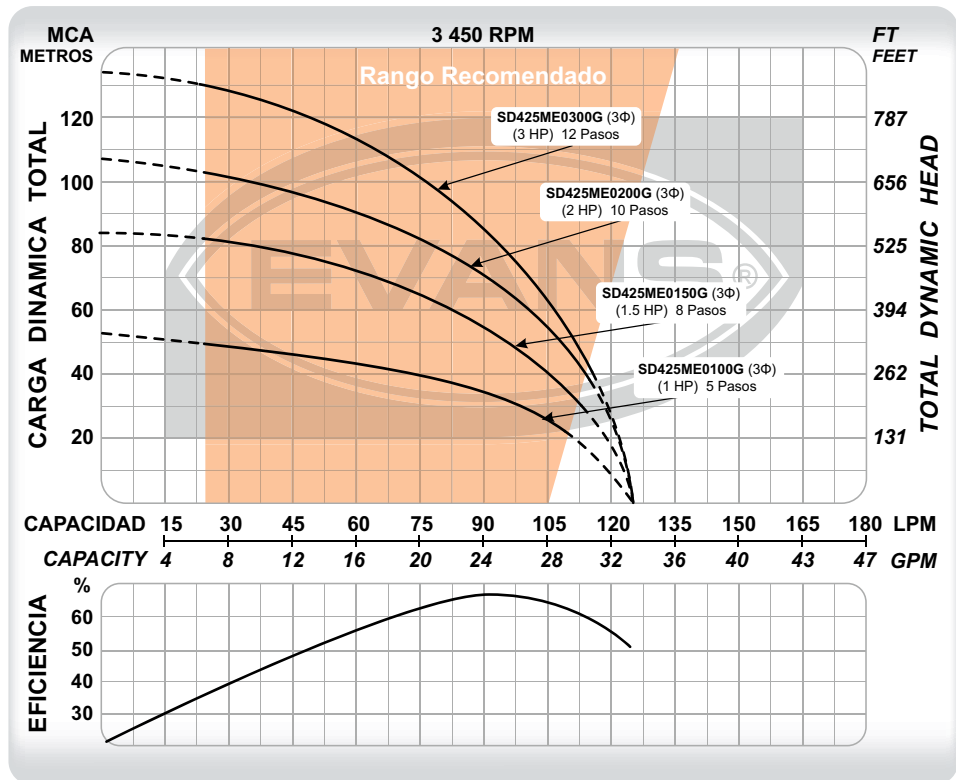

CÓDIGO	PESO	MEDIDAS LARGO x ANCHO x ALTO
SD425ME0100G	13 kg	85 x 12 x 12 cm
SD425ME0150G	16 kg	95 x 12 x 12 cm
SD425ME0200G	18 kg	106 x 12 x 12 cm
SD425ME0300G	20 kg	120 x 12 x 12 cm

CÓDIGO	Ø DESCARGA	POTENCIA	VOLTAJE	CORRIENTE	ETAPAS	FLUJO MÁXIMO	PRESIÓN MÁXIMA	PUNTO DE MAYOR EFICIENCIA
SD425ME0100G	2"	1 HP	220 V ~ 60Hz 3Φ	5.5 A	5	125 l/min	52 m	90 l/min a 32 m
SD425ME0150G	2"	1.5 HP	220 V ~ 60Hz 3Φ	6.4 A	8	125 l/min	83 m	90 l/min a 55 m
SD425ME0200G	2"	2 HP	220 V ~ 60Hz 3Φ	8.2 A	10	125 l/min	109 m	90 l/min a 71 m
SD425ME0300G	2"	3 HP	220 V ~ 60Hz 3Φ	10.9 A	12	125 l/min	132 m	90 l/min a 85 m

BOMBA SUMERGIBLE 4" | 25 GPM

Desempeño de altura



CLASE 1H

1
año
GARANTÍA



- La más resistente a la arena en su categoría.
- Impulsores tipo flotantes fabricados en Noryl®.
- Difusores fabricados en policarbonato.
- Descarga y cople en acero inoxidable extra resistentes.
- Válvula check integrada.



LOS EQUIPOS MONOFÁSICOS INCLUYEN CAJA DE CONTROL METÁLICA HERMÉTICAMENTE SELLADA.

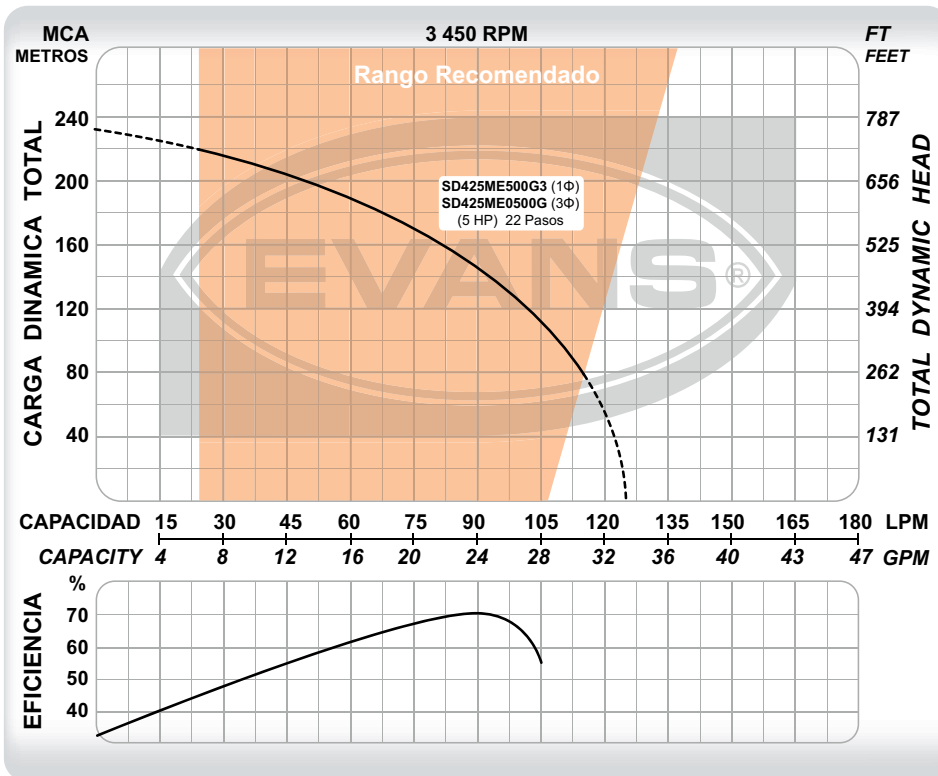

CÓDIGO	PESO	MEDIDAS LARGO x ANCHO x ALTO
SD425ME500G3	30 kg	165 x 26 x 33 cm
SD425ME0500G	29 kg	165 x 26 x 33 cm

CÓDIGO	Ø DESCARGA	POTENCIA	VOLTAJE	CORRIENTE	ETAPAS	FLUJO MÁXIMO	PRESIÓN MÁXIMA	PUNTO DE MAYOR EFICIENCIA
SD425ME500G3	2"	5 HP	220 V ~ 60Hz 1Φ	25.9 A	22	125 l/min	238 m	90 l/min a 141 m
SD425ME0500G	2"	5 HP	220 V ~ 60Hz 3Φ	17.3 A	22	125 l/min	238 m	90 l/min a 141 m



CLASE 1H

BOMBA SUMERGIBLE INOXIDABLE 4" | 25 GPM

Desempeño de altura



- La mejor eficiencia y desempeño en su categoría.
- Impulsores y difusores fabricados en acero inoxidable 304.
- Válvula check integrada.



LOS EQUIPOS MONOFÁSICOS INCLUYEN CAJA DE CONTROL METÁLICA HERMÉTICAMENTE SELLADA.

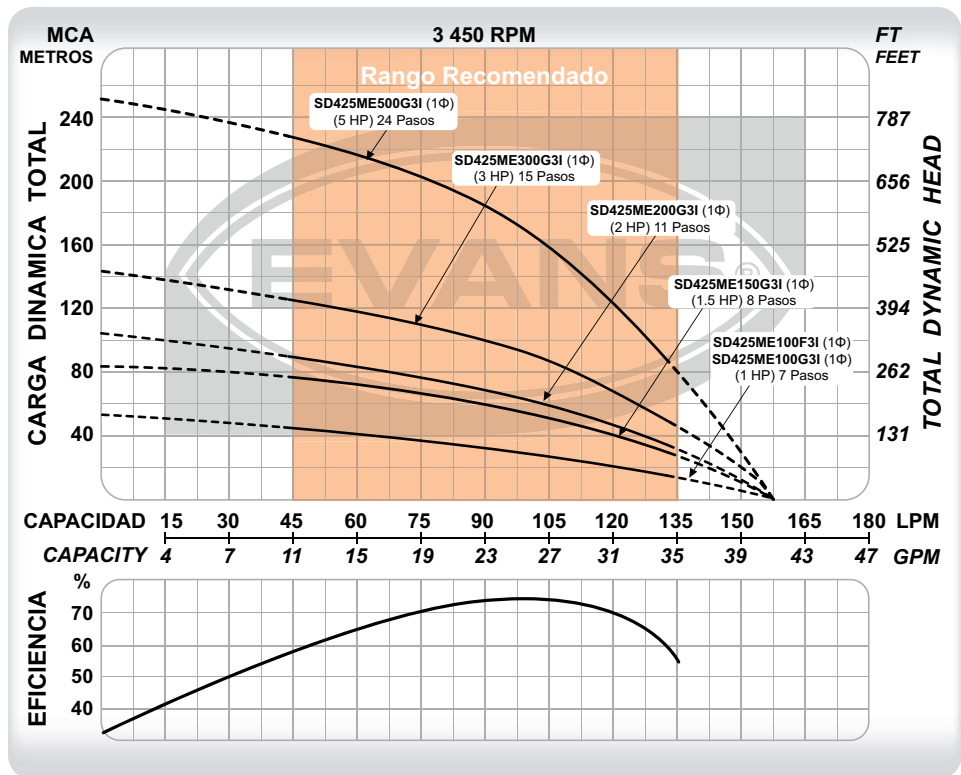

CÓDIGO	PESO	MEDIDAS LARGO x ANCHO x ALTO
SD425ME100F3I	14 kg	85 x 12 x 12 cm
SD425ME100G3I	14 kg	85 x 12 x 12 cm
SD425ME150G3I	15 kg	91 x 12 x 12 cm
SD425ME200G3I	17.5 kg	101 x 12 x 12 cm
SD425ME300G3I	21 kg	114 x 12 x 12 cm
SD425ME500G3I	30 kg	149 x 26 x 33 cm

CÓDIGO	Ø DESCARGA	POTENCIA	VOLTAJE	CORRIENTE	ETAPAS	FLUJO MÁXIMO	PRESIÓN MÁXIMA	PUNTO DE MAYOR EFICIENCIA
SD425ME100F3I	2"	1 HP	110 V ~ 60Hz 1Φ	15.5 A	7	158 l/min	50 m	95 l/min a 35 m
SD425ME100G3I	2"	1 HP	220 V ~ 60Hz 1Φ	7.6 A	7	158 l/min	50 m	95 l/min a 35 m
SD425ME150G3I	2"	1.5 HP	220 V ~ 60Hz 1Φ	9.4 A	8	158 l/min	81 m	95 l/min a 58 m
SD425ME200G3I	2"	2 HP	220 V ~ 60Hz 1Φ	12 A	11	158 l/min	101 m	95 l/min a 68 m
SD425ME300G3I	2"	3 HP	220 V ~ 60Hz 1Φ	15.6 A	15	158 l/min	151 m	95 l/min a 98 m
SD425ME500G3I	2"	5 HP	220 V ~ 60Hz 1Φ	25.9 A	24	158 l/min	252 m	95 l/min a 180 m

BOMBA SUMERGIBLE INOXIDABLE 4" | 25 GPM

Desempeño de altura



CLASE 1H

1
año
GARANTÍA



- La mejor eficiencia y desempeño en su categoría.
- Impulsores y difusores fabricados en acero inoxidable 304.
- Válvula check integrada.

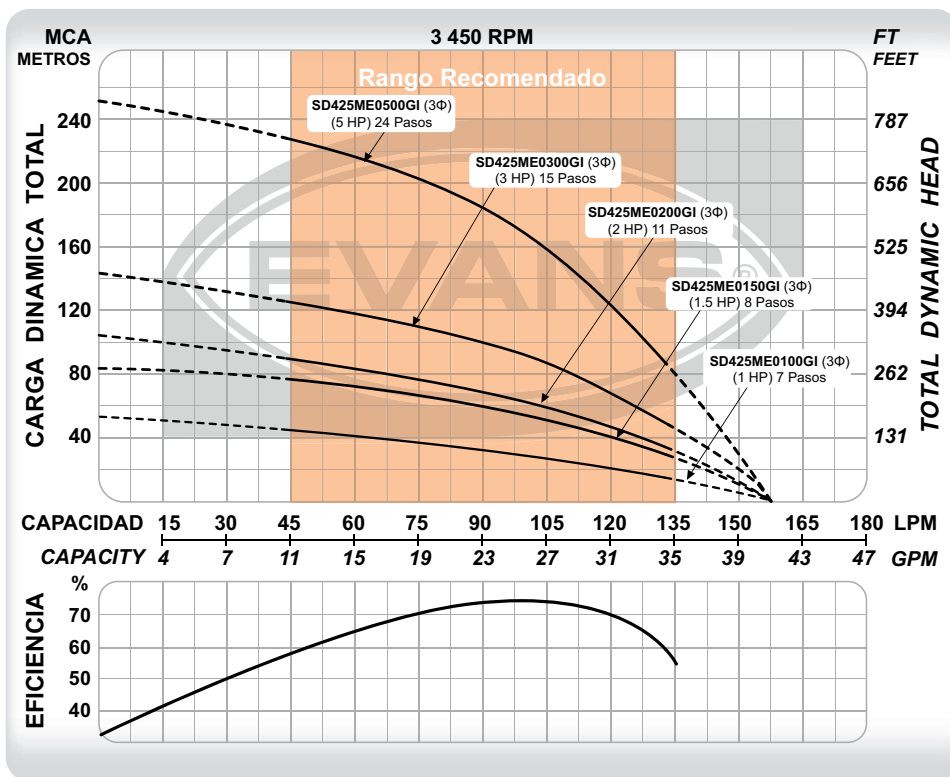

CÓDIGO	PESO	MEDIDAS LARGO x ANCHO x ALTO
SD425ME0100GI	13 kg	90 x 12 x 12 cm
SD425ME0150GI	14 kg	94 x 12 x 12 cm
SD425ME0200GI	16.5 kg	101 x 12 x 12 cm
SD425ME0300GI	20 kg	115 x 12 x 12 cm
SD425ME0500GI	31 kg	149 x 26 x 33 cm

CÓDIGO	Ø DESCARGA	POTENCIA	VOLTAJE	CORRIENTE	ETAPAS	FLUJO MÁXIMO	PRESIÓN MÁXIMA	PUNTO DE MAYOR EFICIENCIA
SD425ME0100GI	2"	1 HP	220 V ~ 60Hz 3Φ	5.5 A	7	158 l/min	50 m	95 l/min a 35 m
SD425ME0150GI	2"	1.5 HP	220 V ~ 60Hz 3Φ	6.4 A	8	158 l/min	81 m	95 l/min a 58 m
SD425ME0200GI	2"	2 HP	220 V ~ 60Hz 3Φ	8.2 A	11	158 l/min	101 m	95 l/min a 68 m
SD425ME0300GI	2"	3 HP	220 V ~ 60Hz 3Φ	10.9 A	15	158 l/min	151 m	95 l/min a 98 m
SD425ME0500GI	2"	5 HP	220 V ~ 60Hz 3Φ	17.3 A	24	158 l/min	252 m	95 l/min a 180 m



CLASE 1H

BOMBA SUMERGIBLE INOXIDABLE 4" | 25 GPM

Desempeño de altura



1
año
GARANTÍA

- La mejor eficiencia y desempeño en su categoría.
- Impulsores y difusores fabricados en acero inoxidable 304.
- Válvula check integrada.

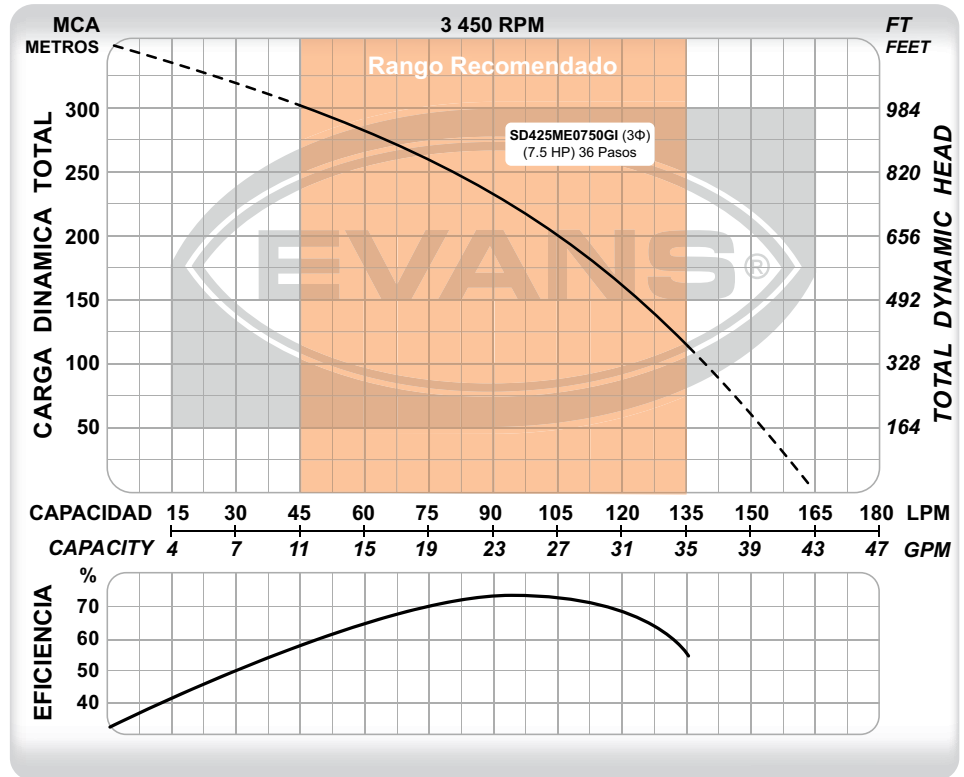

CÓDIGO PESO **MEDIDAS**
LARGO x ANCHO x ALTO
SD425ME0750GI 38 kg 184 x 26 x 33 cm

CÓDIGO	Ø DESCARGA	POTENCIA	VOLTAJE	CORRIENTE	ETAPAS	FLUJO MÁXIMO	PRESIÓN MÁXIMA	PUNTO DE MAYOR EFICIENCIA
SD425ME0750GI	2"	7.5 HP	220 V ~ 60Hz 3Φ	25.9 A	36	165 l/min	350 m	95 l/min a 225 m

BOMBA SUMERGIBLE 4" | 25 GPM

Desempeño de altura



CLASE 1H

1
año
GARANTÍA



- La más resistente a la arena en su categoría.
- Impulsores tipo flotantes fabricados en Noryl®.
- Difusores fabricados en policarbonato.
- Descarga y cople en acero inoxidable extra resistentes.
- Válvula check integrada.



LOS EQUIPOS MONOFÁSICOS INCLUYEN CAJA DE CONTROL METÁLICA HERMÉTICAMENTE SELLADA.

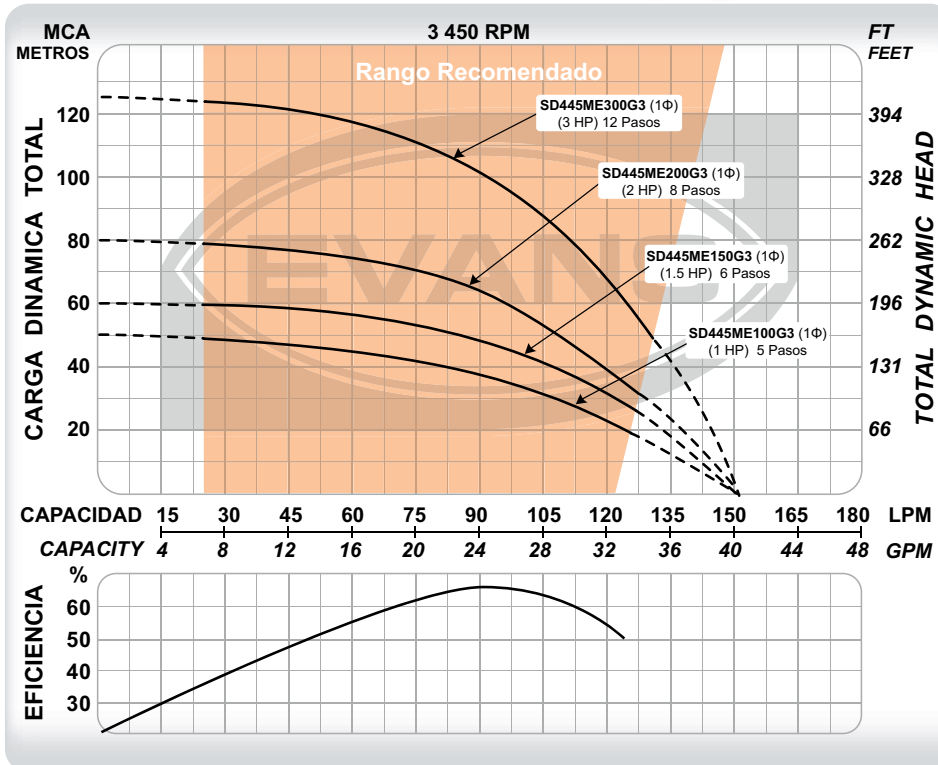

CÓDIGO	PESO	MEDIDAS LARGO x ANCHO x ALTO
SD445ME100G3	14 kg	85 x 12 x 12 cm
SD445ME150G3	16 kg	94 x 12 x 12 cm
SD445ME200G3	18 kg	105 x 12 x 12 cm
SD445ME300G3	22 kg	121 x 12 x 12 cm

CÓDIGO	Ø DESCARGA	POTENCIA	VOLTAJE	CORRIENTE	ETAPAS	FLUJO MÁXIMO	PRESIÓN MÁXIMA	PUNTO DE MAYOR EFICIENCIA
SD445ME100G3	2"	1 HP	220 V ~ 60Hz 1Φ	7.6 A	5	150 l/min	50 m	90 l/min a 38 m
SD445ME150G3	2"	1.5 HP	220 V ~ 60Hz 1Φ	9.4 A	6	150 l/min	60 m	90 l/min a 43 m
SD445ME200G3	2"	2 HP	220 V ~ 60Hz 1Φ	12 A	8	150 l/min	79 m	90 l/min a 62 m
SD445ME300G3	2"	3 HP	220 V ~ 60Hz 1Φ	15.6 A	12	150 l/min	123 m	90 l/min a 99 m



CLASE 1H

BOMBA SUMERGIBLE 4" | 25 GPM

Desempeño de altura



- La más resistente a la arena en su categoría.
- Impulsores tipo flotantes fabricados en Noryl®.
- Difusores fabricados en policarbonato.
- Descarga y cople en acero inoxidable extra resistentes.
- Válvula check integrada.

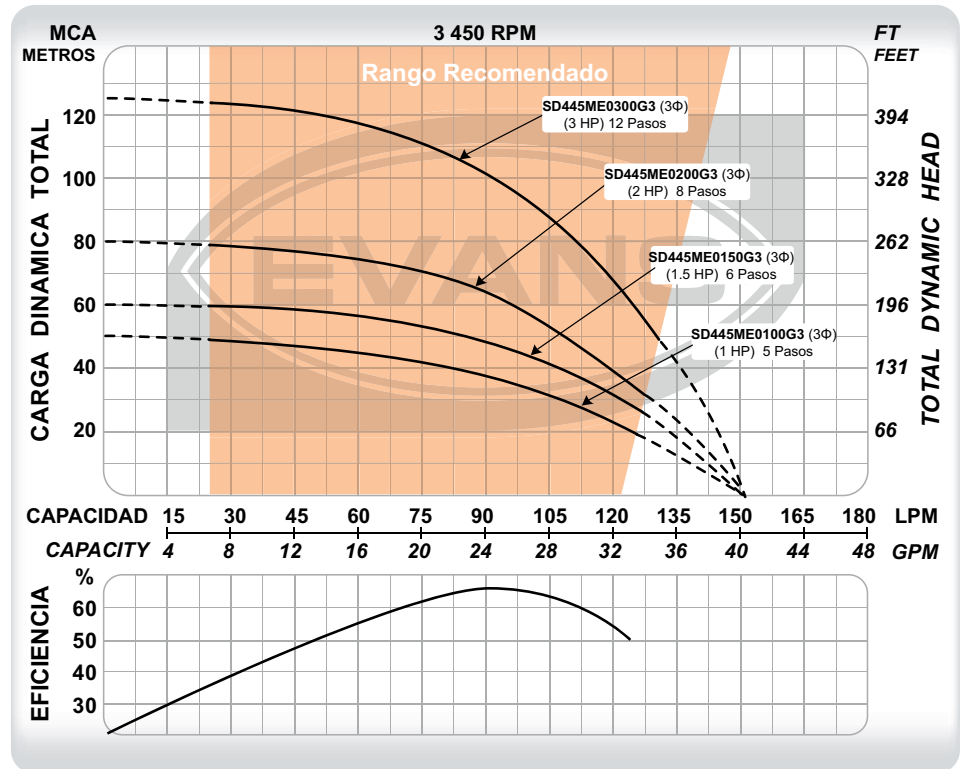

CÓDIGO	PESO	MEDIDAS LARGO x ANCHO x ALTO
SD445ME0100G	14 kg	90 x 12 x 12 cm
SD445ME0150G	15 kg	95 x 12 x 12 cm
SD445ME0200G	18 kg	105 x 12 x 12 cm
SD445ME0300G	20 kg	125 x 12 x 12 cm

CÓDIGO	Ø DESCARGA	POTENCIA	VOLTAJE	CORRIENTE	ETAPAS	FLUJO MÁXIMO	PRESIÓN MÁXIMA	PUNTO DE MAYOR EFICIENCIA
SD445ME0100G	2"	1 HP	220 V ~ 60Hz 3Φ	5.5 A	5	150 l/min	50 m	90 l/min a 38 m
SD445ME0150G	2"	1.5 HP	220 V ~ 60Hz 3Φ	6.4 A	6	150 l/min	60 m	90 l/min a 43 m
SD445ME0200G	2"	2 HP	220 V ~ 60Hz 3Φ	8.2 A	8	150 l/min	79 m	90 l/min a 62 m
SD445ME0300G	2"	3 HP	220 V ~ 60Hz 3Φ	10.9 A	12	150 l/min	123 m	90 l/min a 99 m

BOMBA SUMERGIBLE 4" | 25 GPM

Desempeño de altura



CLASE 1H

1
año
GARANTÍA



- La más resistente a la arena en su categoría.
- Impulsores tipo flotantes fabricados en Noryl®.
- Difusores fabricados en policarbonato.
- Descarga y cople en acero inoxidable extra resistentes.
- Válvula check integrada.

LOS EQUIPOS MONOFÁSICOS INCLUYEN CAJA DE CONTROL METÁLICA HERMÉTICAMENTE SELLADA.

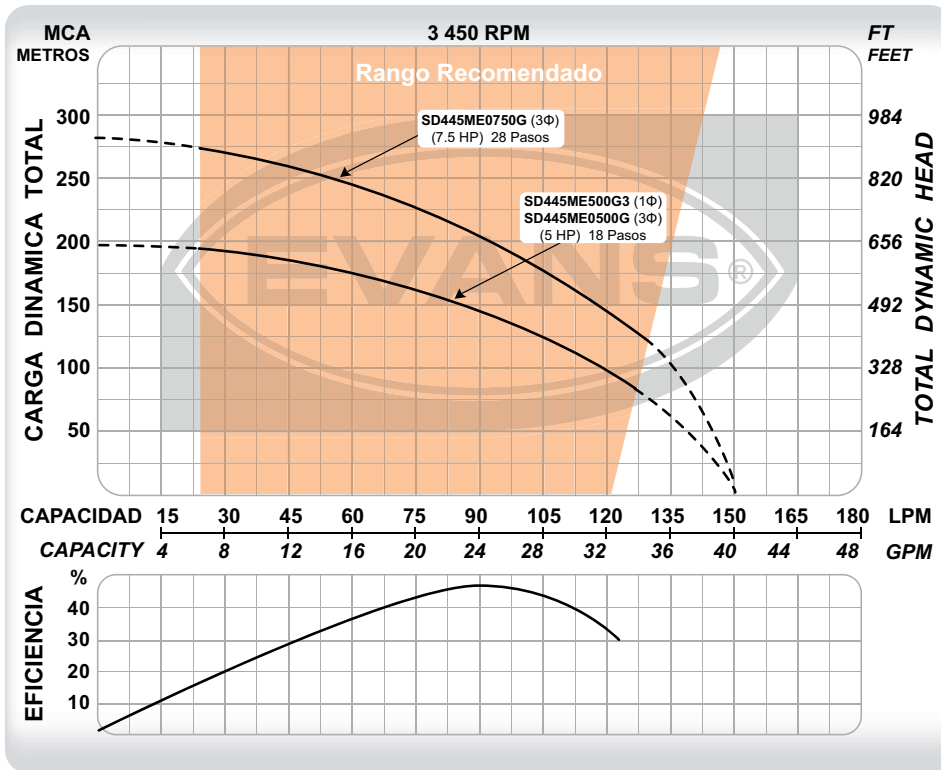

CÓDIGO	PESO	MEDIDAS LARGO x ANCHO x ALTO
SD445ME500G3	31 kg	160 x 26 x 33 cm
SD445ME0500G	30 kg	160 x 26 x 33 cm
SD445ME0750G	41 kg	200 x 26 x 33 cm

CÓDIGO	Ø DESCARGA	POTENCIA	VOLTAJE	CORRIENTE	ETAPAS	FLUJO MÁXIMO	PRESIÓN MÁXIMA	PUNTO DE MAYOR EFICIENCIA
SD445ME500G3	2"	5 HP	220 V ~ 60Hz 1Φ	25.9 A	18	150 l/min	187 m	90 l/min a 145 m
SD445ME0500G	2"	5 HP	220 V ~ 60Hz 3Φ	17.3 A	18	150 l/min	187 m	90 l/min a 145 m
SD445ME0750G	2"	7.5 HP	220 V ~ 60Hz 3Φ	25.9 A	28	150 l/min	282 m	90 l/min a 205 m



CLASE IH

BOMBA SUMERGIBLE 4" | 45 GPM

Desempeño de Altura



1
año
GARANTÍA



- La más resistente a la arena en su categoría.
- Impulsores tipo flotantes fabricados en Noryl®.
- Difusores fabricados en policarbonato.
- Descarga y cople en acero inoxidable extra resistentes.
- Válvula check integrada.



LOS EQUIPOS MONOFÁSICOS INCLUYEN CAJA DE CONTROL METÁLICA HERMÉTICAMENTE SELLADA.

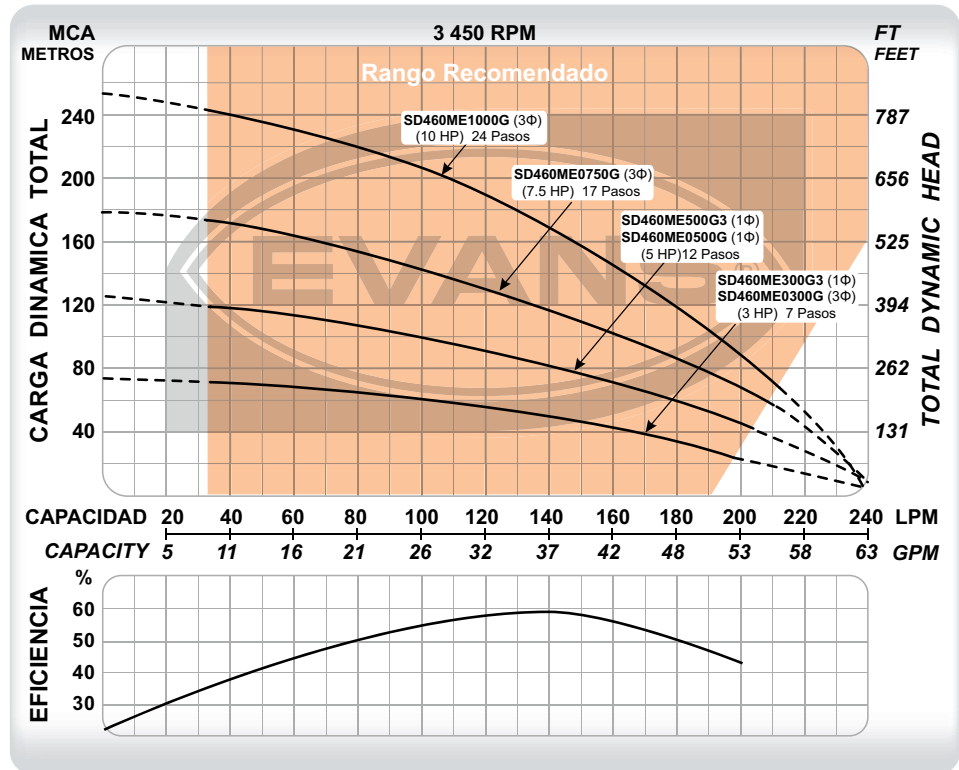

CÓDIGO	PESO	MEDIDAS LARGO x ANCHO x ALTO
SD460ME300G3	21 kg	115 x 12 x 12 cm
SD460ME500G3	30 kg	155 x 26 x 33 cm
SD460ME0300G	20 kg	115 x 12 x 12 cm
SD460ME0500G	29 kg	155 x 26 x 33 cm
SD460ME0750G	37 kg	195 x 26 x 33 cm
SD460ME1000G	46 kg	245 x 26 x 33 cm

CÓDIGO	Ø DESCARGA	POTENCIA	VOLTAJE	CORRIENTE	ETAPAS	FLUJO MÁXIMO	PRESIÓN MÁXIMA	PUNTO DE MAYOR EFICIENCIA
SD460ME300G3	2"	3 HP	220 V ~ 60Hz 1Φ	15.6 A	7	245 l/min	72 m	140 l/min a 50 m
SD460ME500G3	2"	5 HP	220 V ~ 60Hz 1Φ	25.9 A	12	245 l/min	125 m	140 l/min a 80 m
SD460ME0300G	2"	3 HP	220 V ~ 60Hz 3Φ	10.9 A	7	245 l/min	72 m	140 l/min a 50 m
SD460ME0500G	2"	5 HP	220 V ~ 60Hz 3Φ	17.3 A	12	245 l/min	125 m	140 l/min a 80 m
SD460ME0750G	2"	7.5 HP	220 V ~ 60Hz 3Φ	25.9 A	17	245 l/min	178 m	140 l/min a 119 m
SD460ME1000G	2"	10 HP	220 V ~ 60Hz 3Φ	36.2 A	24	245 l/min	248 m	140 l/min a 170 m

BOMBA SUMERGIBLE INOXIDABLE 4" | 45 GPM

Desempeño de altura



CLASE 1H

1
año
GARANTÍA



- La mejor eficiencia y desempeño en su categoría.
- Impulsores y difusores fabricados en acero inoxidable 304.
- Válvula check integrada.



LOS EQUIPOS MONOFÁSICOS INCLUYEN CAJA DE CONTROL METÁLICA HERMÉTICAMENTE SELLADA.

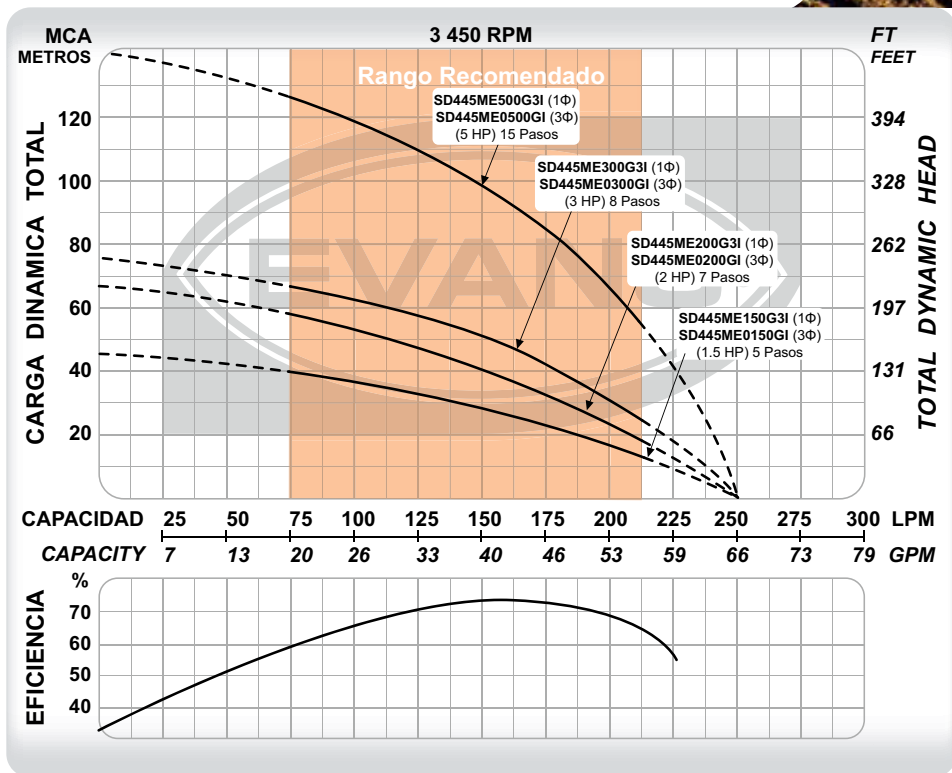

CÓDIGO	PESO	MEDIDAS
		LARGO x ANCHO x ALTO
SD445ME150G3I	14.5 kg	88 x 12 x 12 cm
SD445ME200G3I	17 kg	98 x 12 x 12 cm
SD445ME300G3I	19.5 kg	105 x 12 x 12 cm
SD445ME500G3I	29 kg	138 x 26 x 33 cm
SD445ME0150GI	14.5 kg	91 x 12 x 12 cm
SD445ME0200GI	16 kg	97 x 12 x 12 cm
SD445ME0300GI	19 kg	106 x 12 x 12 cm
SD445ME0500GI	30 kg	138 x 26 x 33 cm

CÓDIGO	Ø DESCARGA	POTENCIA	VOLTAJE	CORRIENTE	ETAPAS	FLUJO MÁXIMO	PRESIÓN MÁXIMA	PUNTO DE MAYOR EFICIENCIA
SD445ME150G3I	2"	1.5 HP	220 V ~ 60Hz 1Φ	9.4 A	5	250 l/min	48 m	155 l/min a 28 m
SD445ME200G3I	2"	2 HP	220 V ~ 60Hz 1Φ	12 A	7	250 l/min	67 m	155 l/min a 40 m
SD445ME300G3I	2"	3 HP	220 V ~ 60Hz 1Φ	15.6 A	8	250 l/min	75 m	155 l/min a 50 m
SD445ME500G3I	2"	5 HP	220 V ~ 60Hz 1Φ	25.9 A	15	250 l/min	140 m	155 l/min a 98 m
SD445ME0150GI	2"	1.5 HP	220 V ~ 60Hz 3Φ	6.4 A	5	250 l/min	48 m	155 l/min a 28 m
SD445ME0200GI	2"	2 HP	220 V ~ 60Hz 3Φ	8.2 A	7	250 l/min	67 m	155 l/min a 40 m
SD445ME0300GI	2"	3 HP	220 V ~ 60Hz 3Φ	10.9 A	8	250 l/min	75 m	155 l/min a 50 m
SD445ME0500GI	2"	5 HP	220 V ~ 60Hz 3Φ	17.3 A	15	250 l/min	140 m	155 l/min a 98 m



CLASE 1H

BOMBA SUMERGIBLE INOXIDABLE 4" | 45 GPM

Desempeño de altura



1
año
GARANTÍA



- La mejor eficiencia y desempeño en su categoría.
- Impulsores y difusores fabricados en acero inoxidable 304.
- Válvula check integrada.

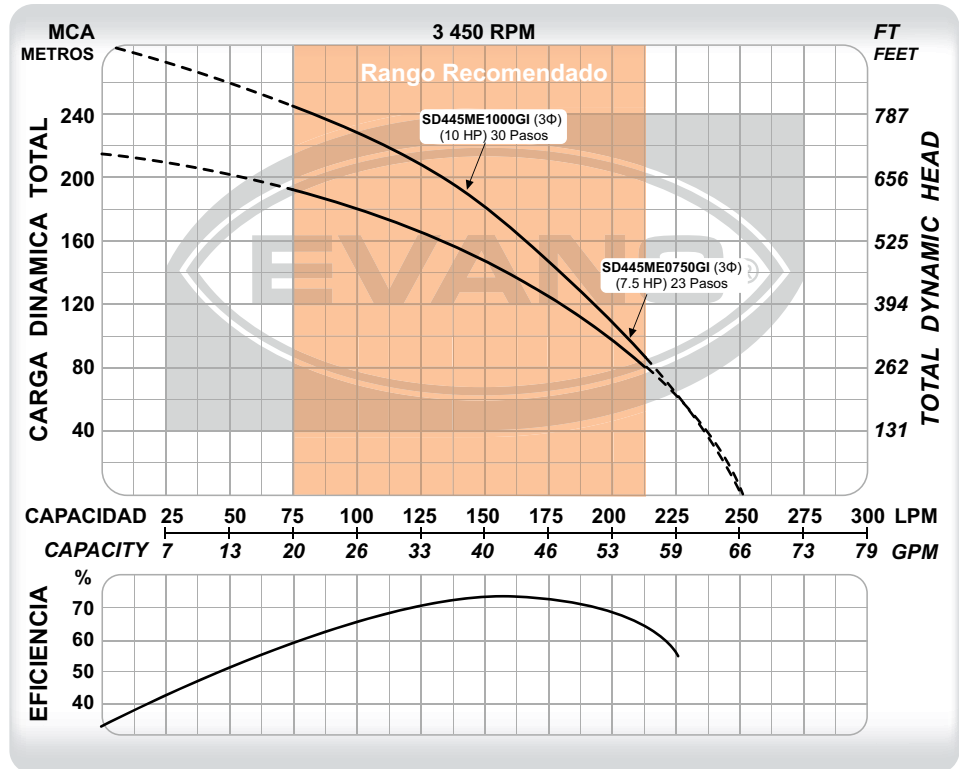

CÓDIGO	PESO	MEDIDAS LARGO x ANCHO x ALTO
SD445ME0750GI	36 kg	169 x 26 x 33 cm
SD445ME1000GI	45 kg	205 x 26 x 36 cm

CÓDIGO	Ø DESCARGA	POTENCIA	VOLTAJE	CORRIENTE	ETAPAS	FLUJO MÁXIMO	PRESIÓN MÁXIMA	PUNTO DE MAYOR EFICIENCIA
SD445ME0750GI	2"	7.5 HP	220 V ~ 60Hz 3Φ	25.9 A	23	250 l/min	219 m	155 l/min a 147 m
SD445ME1000GI	2"	10 HP	220 V ~ 60Hz 3Φ	36.2 A	30	250 l/min	290 m	155 l/min a 180 m

BOMBA SUMERGIBLE 4" | 60 GPM

Desempeño de altura



CLASE IH

1
año
GARANTÍA



- La más resistente a la arena en su categoría.
- Impulsores tipo flotantes fabricados en Noryl®.
- Difusores fabricados en policarbonato.
- Descarga y cople en acero inoxidable extra resistentes.
- Válvula check integrada.

LOS EQUIPOS MONOFÁSICOS INCLUYEN CAJA DE CONTROL METÁLICA HERMÉTICAMENTE SELLADA.

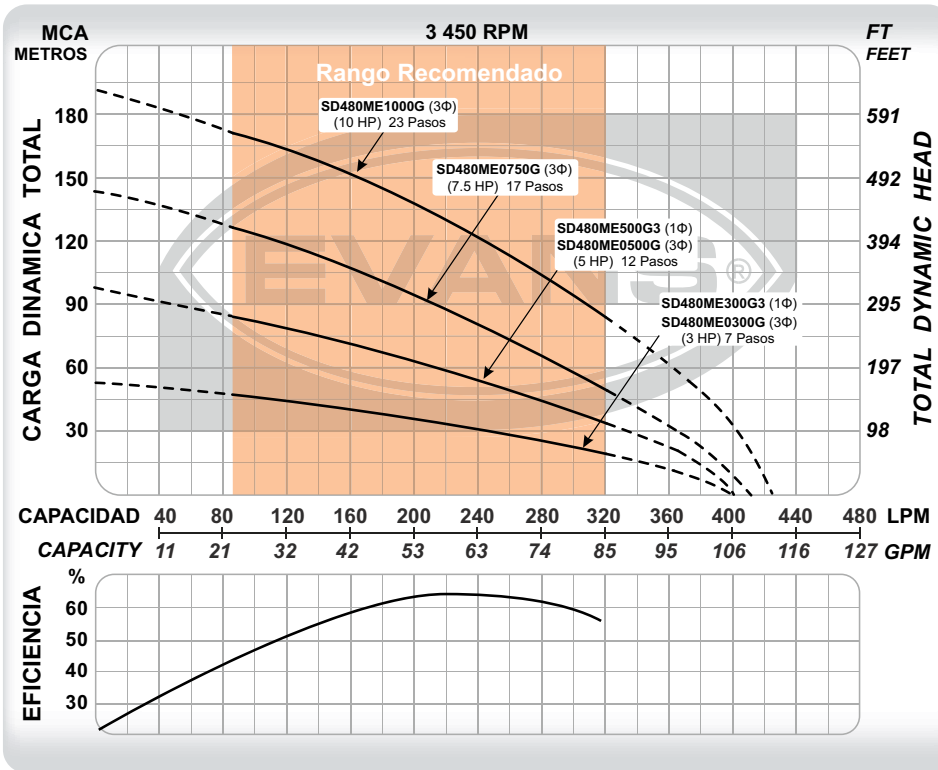

CÓDIGO	PESO	MEDIDAS LARGO x ANCHO x ALTO
SD480ME300G3	22 kg	130 x 12 x 12 cm
SD480ME500G3	32 kg	175 x 26 x 33 cm
SD480ME0300G	21 kg	130 x 12 x 12 cm
SD480ME0500G	31 kg	175 x 26 x 33 cm
SD480ME0750G	40 kg	230 x 26 x 33 cm
SD480ME1000G	50 kg	287 x 26 x 33 cm

CÓDIGO	Ø DESCARGA	POTENCIA	VOLTAJE	CORRIENTE	ETAPAS	FLUJO MÁXIMO	PRESIÓN MÁXIMA	PUNTO DE MAYOR EFICIENCIA
SD480ME300G3	2"	3 HP	220 V ~ 60Hz 1Φ	15.6 A	7	395 l/min	56 m	230 l/min a 32 m
SD480ME500G3	2"	5 HP	220 V ~ 60Hz 1Φ	25.9 A	12	395 l/min	96 m	230 l/min a 57 m
SD480ME0300G	2"	3 HP	220 V ~ 60Hz 3Φ	10.9 A	7	395 l/min	56 m	230 l/min a 32 m
SD480ME0500G	2"	5 HP	220 V ~ 60Hz 3Φ	17.3 A	12	395 l/min	96 m	230 l/min a 57 m
SD480ME0750G	2"	7.5 HP	220 V ~ 60Hz 3Φ	25.9 A	17	410 l/min	145 m	230 l/min a 80 m
SD480ME1000G	2"	10 HP	220 V ~ 60Hz 3Φ	36.2 A	23	420 l/min	191 m	230 l/min a 127 m



CLASE 1H

BOMBA SUMERGIBLE INOXIDABLE 4" | 60 GPM

Desempeño de altura



1
año
GARANTÍA



- La mejor eficiencia y desempeño en su categoría.
- Impulsores y difusores fabricados en acero inoxidable 304.
- Válvula check integrada.



LOS EQUIPOS MONOFÁSICOS INCLUYEN CAJA DE CONTROL METÁLICA HERMÉTICAMENTE SELLADA.

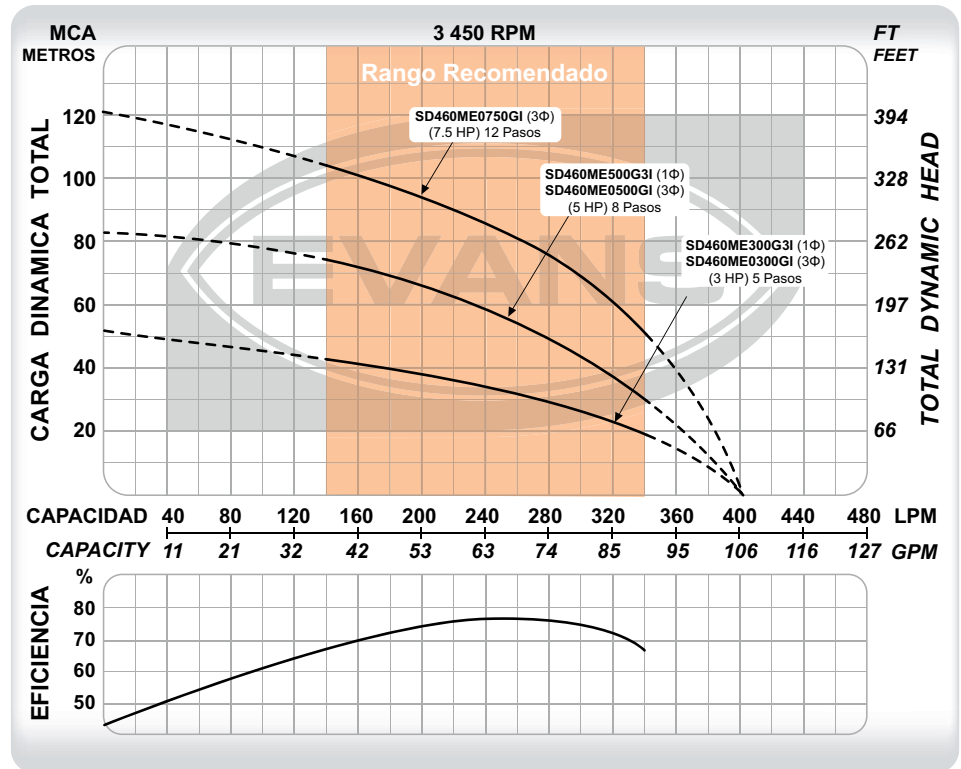

CÓDIGO	PESO	MEDIDAS LARGO x ANCHO x ALTO
SD460ME300G3I	20 kg	108 x 12 x 12 cm
SD460ME500G3I	29 kg	137 x 26 x 33 cm
SD460ME0300GI	19.5 kg	109 x 12 x 12 cm
SD460ME0500GI	30 kg	137 x 26 x 33 cm
SD460ME0750GI	37 kg	169 x 26 x 33 cm

CÓDIGO	Ø DESCARGA	POTENCIA	VOLTAJE	CORRIENTE	ETAPAS	FLUJO MÁXIMO	PRESIÓN MÁXIMA	PUNTO DE MAYOR EFICIENCIA
SD460ME300G3I	2"	3 HP	220 V ~ 60Hz 1Φ	15.6 A	5	400 l/min	51 m	240 l/min a 34 m
SD460ME500G3I	2"	5 HP	220 V ~ 60Hz 1Φ	25.9 A	8	400 l/min	82 m	240 l/min a 59 m
SD460ME0300GI	2"	3 HP	220 V ~ 60Hz 3Φ	10.9 A	5	400 l/min	51 m	240 l/min a 34 m
SD460ME0500GI	2"	5 HP	220 V ~ 60Hz 3Φ	17.3 A	8	400 l/min	82 m	240 l/min a 59 m
SD460ME0750GI	2"	7.5 HP	220 V ~ 60Hz 3Φ	25.9 A	12	400 l/min	120 m	240 l/min a 85 m

BOMBA SUMERGIBLE INOXIDABLE 4" | 60 GPM

Desempeño de altura

CLASE 1H



1
año
GARANTÍA



- La mejor eficiencia y desempeño en su categoría.
- Impulsores y difusores fabricados en acero inoxidable 304.
- Válvula check integrada.

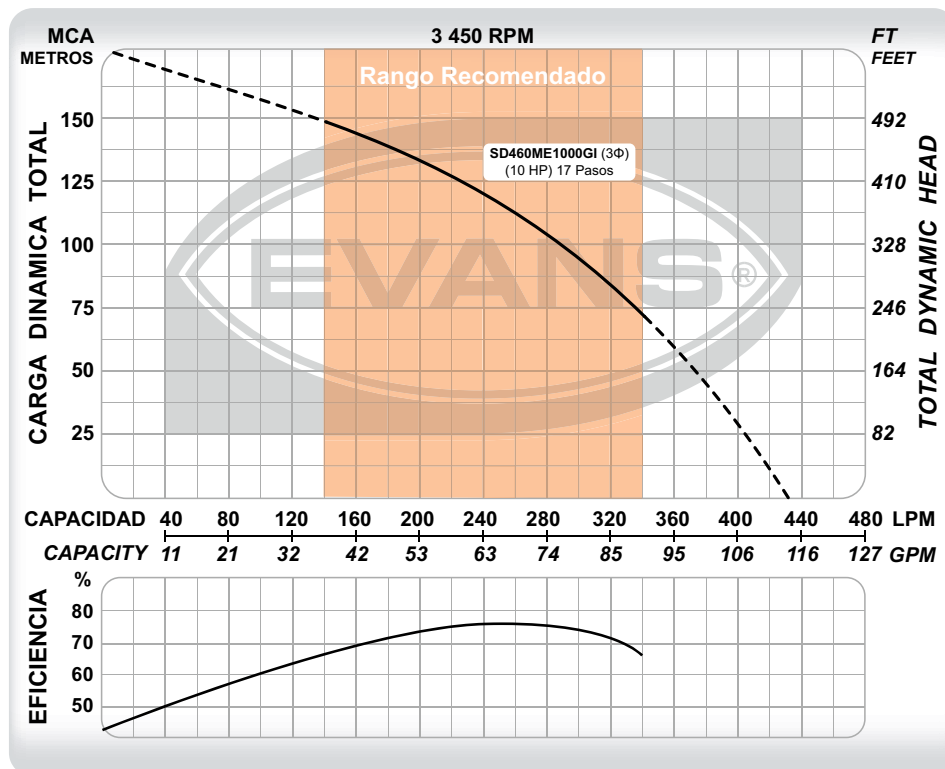
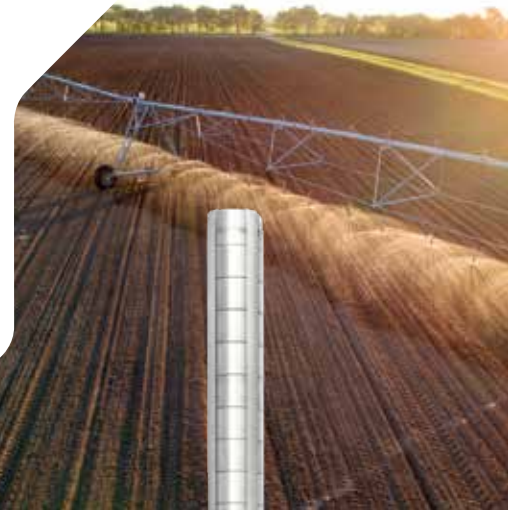

CÓDIGO	PESO	MEDIDAS
		LARGO x ANCHO x ALTO
SD460ME1000GI	46.5 kg	207 x 26 x 33 cm

CÓDIGO	Ø DESCARGA	POTENCIA	VOLTAJE	CORRIENTE	ETAPAS	FLUJO MÁXIMO	PRESIÓN MÁXIMA	PUNTO DE MAYOR EFICIENCIA
SD460ME1000GI	2"	10 HP	220 V ~ 60Hz 3Φ	36.2 A	17	430 l/min	175 m	240 l/min a 117 m



- La más resistente a la arena en su categoría.
- Impulsores tipo flotantes fabricados en Noryl®.
- Difusores fabricados en policarbonato.
- Descarga y cople en acero inoxidable extra resistentes.
- Válvula check integrada.



LOS EQUIPOS MONOFÁSICOS INCLUYEN CAJA DE CONTROL METÁLICA HERMÉTICAMENTE SELLADA.



CÓDIGO	PESO	MEDIDAS LARGO x ANCHO x ALTO
SD4100ME300G3	19 kg	115 x 12 x 12 cm
SD4100ME500G3	27 kg	140 x 26 x 33 cm
SD4100ME0300G	18 kg	130 x 12 x 12 cm
SD4100ME0500G	26 kg	140 x 26 x 33 cm
SD4100ME0750G	36 kg	180 x 26 x 33 cm
SD4100ME1000G	44 kg	220 x 26 x 33 cm
SD4100ME1250G	50 kg	250 x 26 x 33 cm

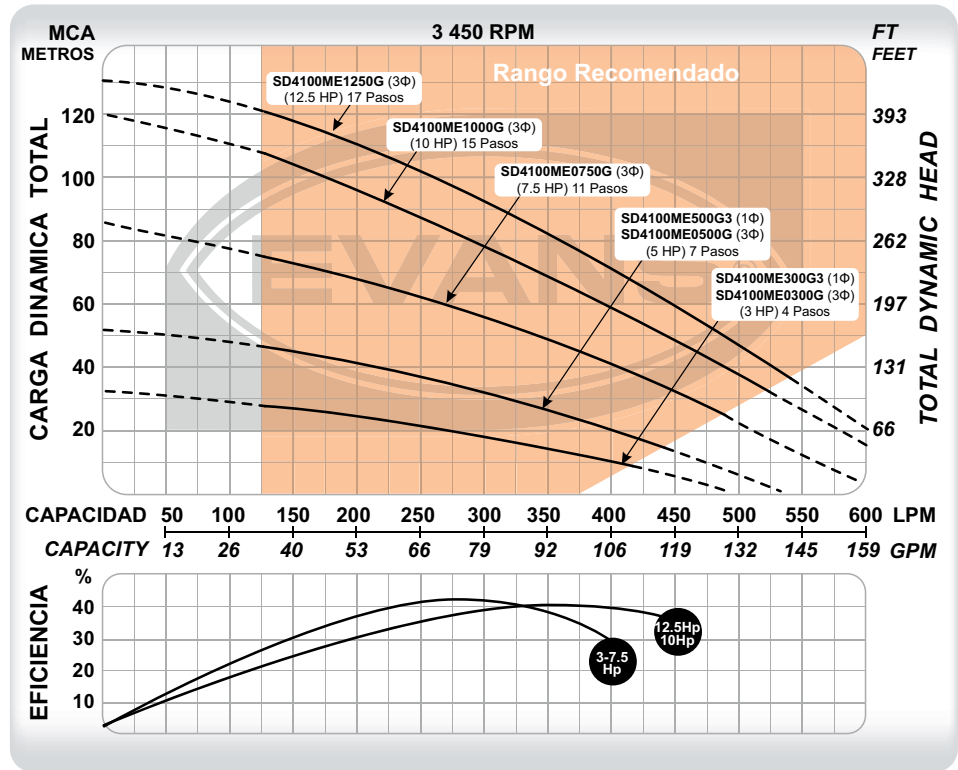

CÓDIGO	Ø DESCARGA	POTENCIA	VOLTAJE	CORRIENTE	ETAPAS	FLUJO MÁXIMO	PRESIÓN MÁXIMA	PUNTO DE MAYOR EFICIENCIA
SD4100ME300G3	2"	3 HP	220 V ~ 60Hz 1Φ	15.9 A	4	485 l/min	31 m	270 l/min a 20 m
SD4100ME500G3	2"	5 HP	220 V ~ 60Hz 1Φ	25.9 A	7	485 l/min	55 m	270 l/min a 35 m
SD4100ME0300G	2"	3 HP	220 V ~ 60Hz 3Φ	10.9 A	4	485 l/min	31 m	270 l/min a 20 m
SD4100ME0500G	2"	5 HP	220 V ~ 60Hz 3Φ	17.3 A	7	485 l/min	55 m	270 l/min a 35 m
SD4100ME0750G	2"	7.5 HP	220 V ~ 60Hz 3Φ	29.9 A	11	600 l/min	85 m	270 l/min a 59 m
SD4100ME1000G	2"	10 HP	220 V ~ 60Hz 3Φ	36.2 A	15	630 l/min	119 m	370 l/min a 64 m
SD4100ME1250G	2"	12.5 HP	220 V ~ 60Hz 3Φ	44.9 A	17	630 l/min	135 m	370 l/min a 75 m

1
año
GARANTÍA



COMPONENTES

No.	PARTE
1	Soporte motor
2	O-ring inferior
3	Soporte inferior
4	Carcasa del motor
5	Estator
6	Rotor
7	Soporte superior
8	Glándula del cable
9	Cable
10	Cubierta anti arena
11	Sello superior
12	Sello mecánico
13	O-ring superior
14	Rodamiento superior
15	Rodamiento inferior
16	Diafragma de compensación de presión
17	Protección contra impacto inferior
18	Anillo de sujeción

MATERIALES DE MOTOR

Material del cuerpo	AISI 304
Rotor / Flecha	AISI 431. Una sola pieza
Sello mecánico	Grafito /cerámica / NBR / AISI 304
Rodamientos de empuje	Acero 2Cr13, AISI304 y Carburo de silicio
Campana	AISI 304
Tornillería	AISI 304
Submersibilidad	300 m
Acoplamiento	NEMA
Aislamiento	Clase F
Temperatura máx.	30 °C
PH del agua	5.5 - 8.9

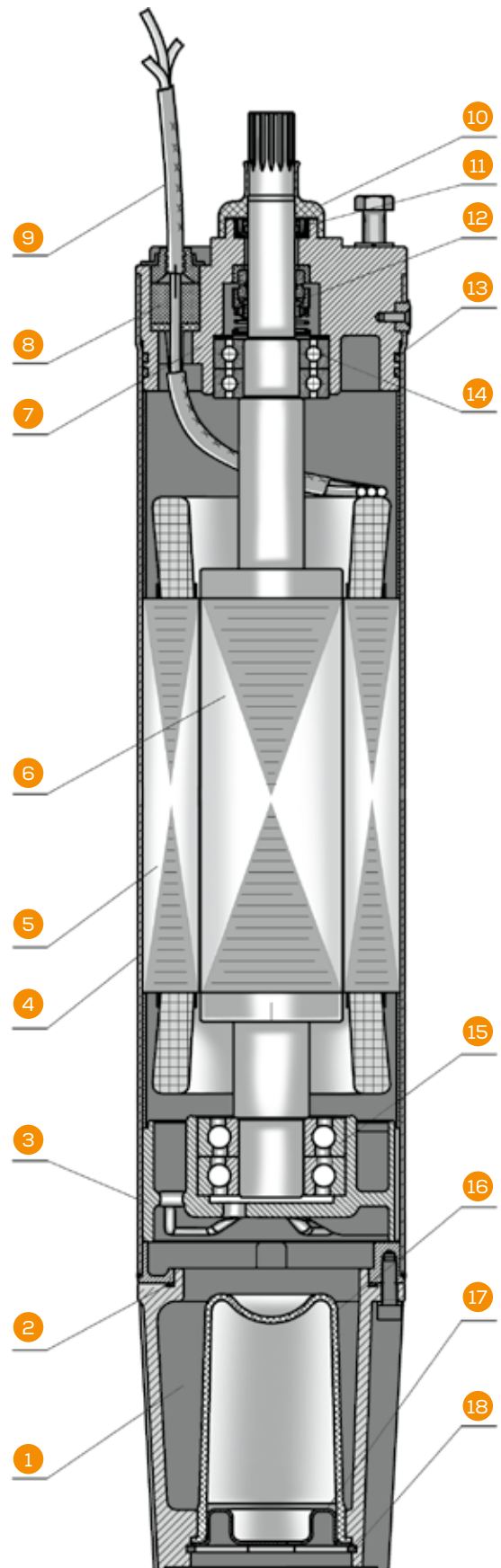

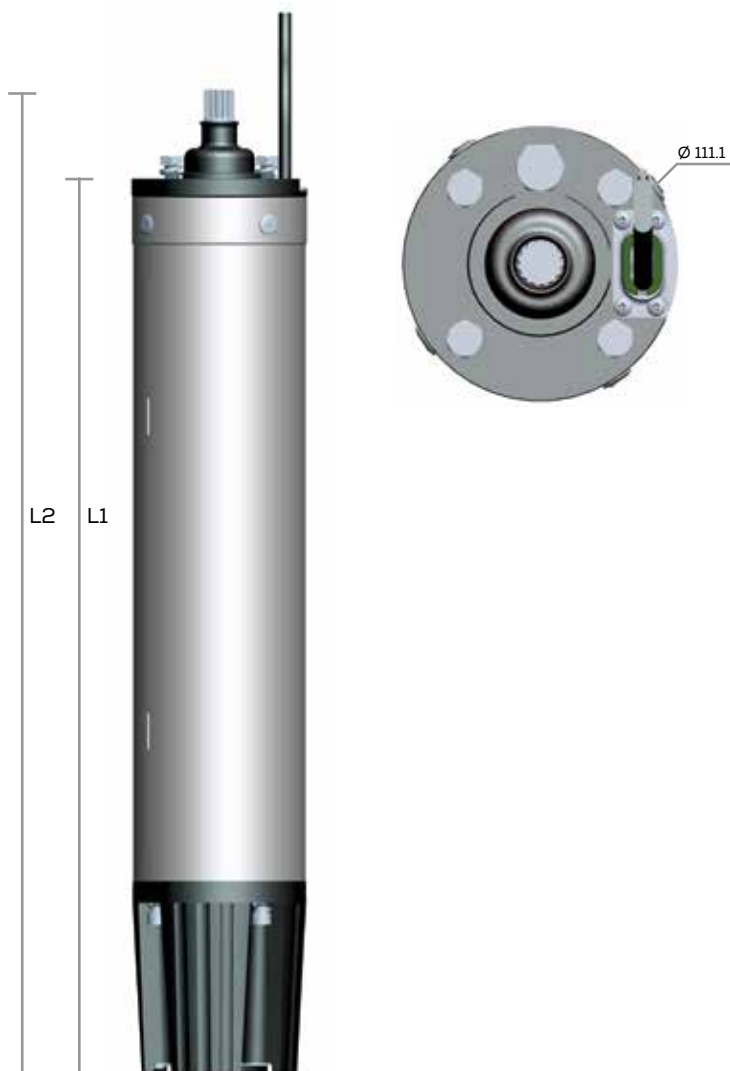

CARACTERÍSTICAS GENERALES

- Los motores sumergibles EVANS® de 6" tienen un mecanismo de enfriamiento a base de aceite de origen vegetal.
- Son compatible con las unidades de bombeo de diferentes marcas que tengan cumplimiento NEMA.
- Acoplamiento NEMA 6.
- Motor con embobinado de cobre y aislamiento CLASE F, cumpliendo con los estándares de NEMA MW37-C.
- Rodamientos suecos tipo bola de contacto angular especialmente diseñados para el trabajo continuo y soportar mayores cargas axiales.
- Altamente eficientes con la vida útil más larga del mercado. Soporta hasta 20 arranques por hora.

PESOS Y MEDIDAS

CÓDIGO	POTENCIA (HP)	L 1 (cm)	L 2 (cm)	PESO (kg)	VOLTAJE	CORRIENTE NOMINAL (A)	FACTOR SERVICIO	CORRIENTE MÁX. (A)	EMPUJE AXIAL (N)	
E26S1000G-P	10	62	69.3	34.4	220V ~ 60Hz 3Φ	30.4	1.15	35	15500	
E26S1000H-P					440V ~ 60Hz 3Φ	15.2		17.5		
E26S1500G-P	15	68.5	75.8	41.4	220V ~ 60Hz 3Φ	43.2		49.7		
E26S1500H-P					440V ~ 60Hz 3Φ	21.6		24.8		
E26S2000G-P	20	75.5	82.8	58.3	220V ~ 60Hz 3Φ	56.4		64.9		
E26S2000H-P					440V ~ 60Hz 3Φ	28.2		32.4		
E26S2500G-P	25	82	89.3	61	220V ~ 60Hz 3Φ	69		79.4		30000
E26S2500H-P					440V ~ 60Hz 3Φ	34.5		39.7		
E26S3000G-P	30	88	95.3	95.3	220V ~ 60Hz 3Φ	81.6		93.8		
E26S3000H-P					440V ~ 60Hz 3Φ	40.8		46.9		
E26S3500H-P	35	93	100.3	100.3	440V ~ 60Hz 3Φ	51	58.7			
E26S4000H-P	40	98	105.3	105.3	440V ~ 60Hz 3Φ	56.7	65.2			
E26S5000H-P	50	111.8	119.1	119.1	440V ~ 60Hz 3Φ	75	86.3			

CARACTERÍSTICAS GENERALES DE UNIDAD DE BOMBEO DE 6" EN ACERO INOXIDABLE



1
año
GARANTÍA



COMPONENTES

No.	PARTE
1	Guardacable
2	Válvula check
3	Tuerca del separador
4	Flecha
5	Rodamiento
6	Difusor
7	Anillo de sellado
8	Impulsor
9	Separador de etapas
10	Anillo de sujeción
11	Rejilla de succión
12	Tornillo
13	Tuerca
14	Cople

MATERIALES DE UNIDAD DE BOMBEO

Material del cuerpo	AISI 304
Descarga	AISI 304
Succión	AISI 304
Flecha de bomba	AISI 431
Cople	AISI 304
Protector de cable	AISI 304
SopORTE de válvula check	AISI 304
Impulsores	AISI 304
Difusores	AISI 304
Válvula check	AISI 304
Rodamientos de bomba	Buna-N
Acoplamiento	NEMA
Máx. contenido de arena	5% ~ 50g/m ³
PH del agua	5.5 - 8.9

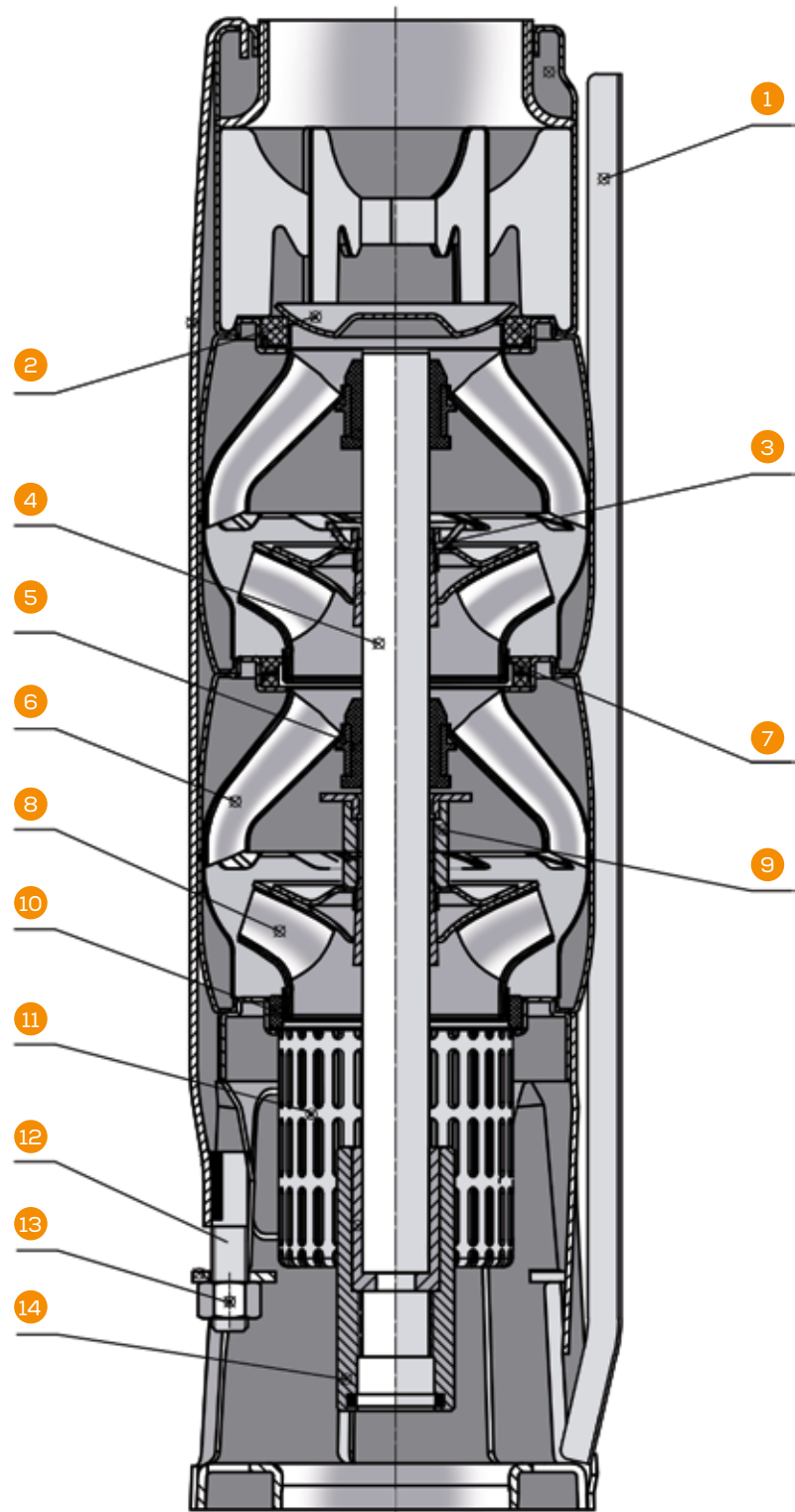



CLASE 10

BOMBA SUMERGIBLE INOXIDABLE 6" | 90 GPM

Desempeño de altura



1
año
GARANTÍA

- Bombas sumergibles para pozos profundos.
- La más eficiente en su categoría: mayor presión y flujo con menor consumo energético.
- Fabricación 100% en acero inoxidable 304.
- Válvula check integrada.

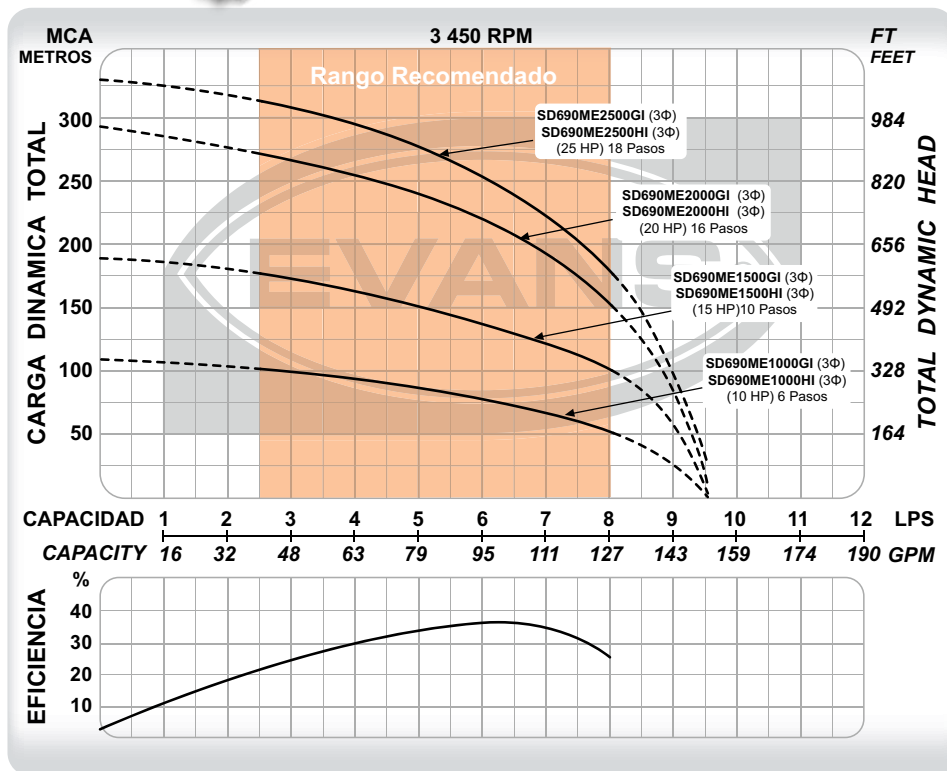

CÓDIGO	PESO	MEDIDAS
		LARGO x ANCHO x ALTO
SD690ME1000GI	52 kg	138 x 31 x 43 cm
SD690ME1500GI	63 kg	163 x 31 x 43 cm
SD690ME2000GI	85 kg	197 x 31 x 43 cm
SD690ME2500GI	90 kg	212 x 31 x 43 cm
SD690ME1000HI	52 kg	138 x 31 x 43 cm
SD690ME1500HI	63 kg	163 x 31 x 43 cm
SD690ME2000HI	85 kg	197 x 31 x 43 cm
SD690ME2500HI	90 kg	212 x 31 x 43 cm

CÓDIGO	Ø DESCARGA	POTENCIA	VOLTAJE	CORRIENTE	ETAPAS	FLUJO MÁXIMO	PRESIÓN MÁXIMA	PUNTO DE MAYOR EFICIENCIA
SD690ME1000GI	3"	10 HP	220 V ~ 60Hz 3Φ	35 A	6	9.5 l/s	108 m	6 l/s a 75 m
SD690ME1500GI	3"	15 HP	220 V ~ 60Hz 3Φ	49.7 A	10	9.5 l/s	181 m	6 l/s a 135 m
SD690ME2000GI	3"	20 HP	220 V ~ 60Hz 3Φ	64.9 A	16	9.5 l/s	289 m	6 l/s a 220 m
SD690ME2500GI	3"	25 HP	220 V ~ 60Hz 3Φ	79.4 A	18	9.5 l/s	326 m	6 l/s a 237 m
SD690ME1000HI	3"	10 HP	440 V ~ 60Hz 3Φ	17.5 A	6	9.5 l/s	108 m	6 l/s a 75 m
SD690ME1500HI	3"	15 HP	440 V ~ 60Hz 3Φ	24.8 A	10	9.5 l/s	181 m	6 l/s a 135 m
SD690ME2000HI	3"	20 HP	440 V ~ 60Hz 3Φ	32.4 A	16	9.5 l/s	289 m	6 l/s a 220 m
SD690ME2500HI	3"	25 HP	440 V ~ 60Hz 3Φ	39.7 A	18	9.5 l/s	326 m	6 l/s a 250 m

BOMBA SUMERGIBLE INOXIDABLE 6" | 90 GPM

Desempeño de altura



CLASE 10

1
año
GARANTÍA



- Bombas sumergibles para pozos profundos.
- La más eficiente en su categoría: mayor presión y flujo con menor consumo energético.
- Fabricación 100% en acero inoxidable 304.
- Válvula check integrada.

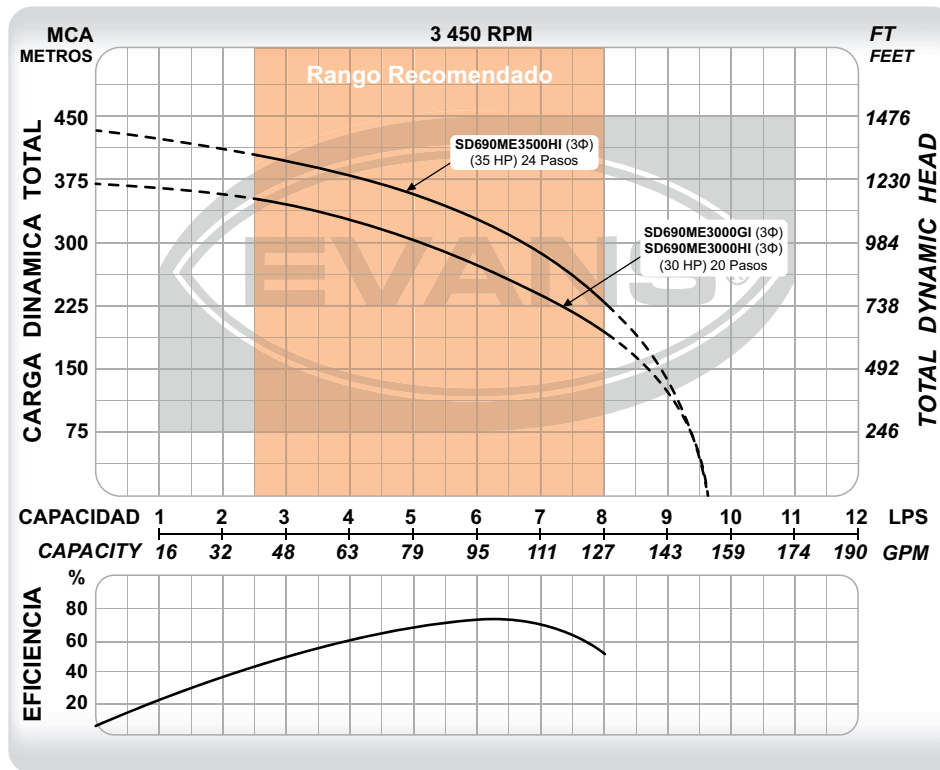

CÓDIGO	PESO	MEDIDAS LARGO x ANCHO x ALTO
SD690ME3000GI	101 kg	227 x 31 x 43 cm
SD690ME3000HI	101 kg	227 x 31 x 43 cm
SD690ME3500HI	113 kg	250 x 31 x 43 cm

CÓDIGO	Ø DESCARGA	POTENCIA	VOLTAJE	CORRIENTE	ETAPAS	FLUJO MÁXIMO	PRESIÓN MÁXIMA	PUNTO DE MAYOR EFICIENCIA
SD690ME3000GI	3"	30 HP	220 V ~ 60Hz 3Φ	93.8 A	20	9.5 l/s	361 m	6 l/s a 260 m
SD690ME3000HI	3"	30 HP	440 V ~ 60Hz 3Φ	46.9 A	20	9.5 l/s	361 m	6 l/s a 260 m
SD690ME3500HI	3"	35 HP	440 V ~ 60Hz 3Φ	58.7 A	24	9.5 l/s	433 m	6 l/s a 325 m

Desempeño de altura



- Bombas sumergibles para pozos profundos.
- La más resistente a la arena en su categoría.
- Impulsores tipo flotantes fabricados en Noryl®.
- Difusores fabricados en policarbonato.
- Descarga y cople en acero inoxidable extra resistentes.
- Válvula check integrada.

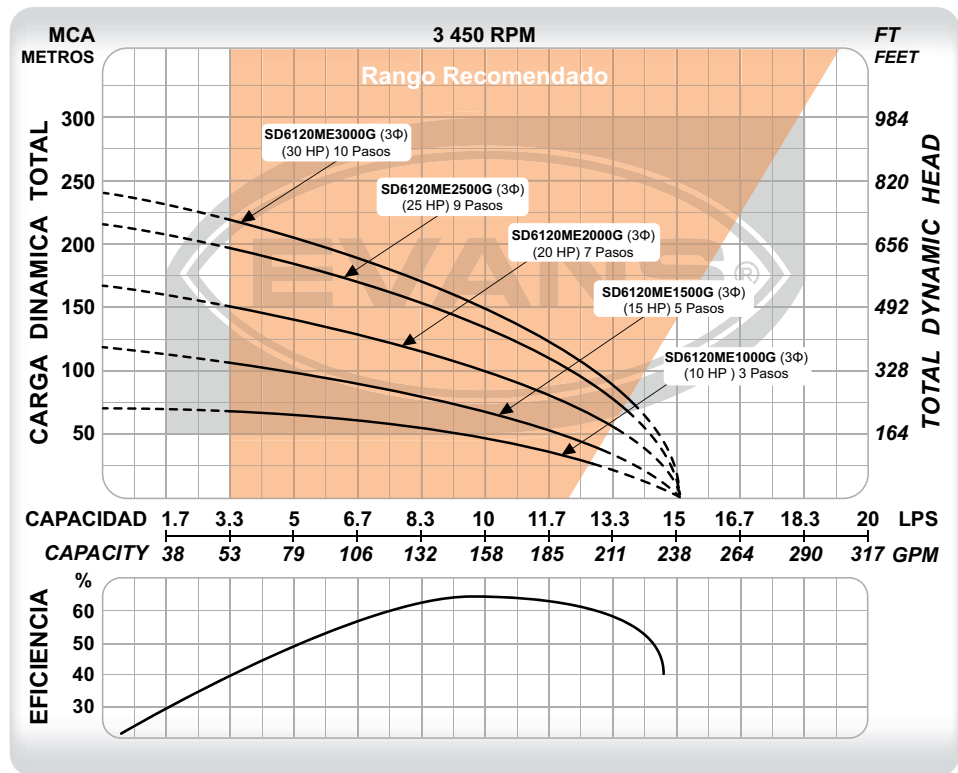

CÓDIGO	PESO	MEDIDAS LARGO x ANCHO x ALTO
SD6120ME1000G	66.5 kg	133 x 31 x 43cm
SD6120ME1500G	75 kg	148 x 31 x 43cm
SD6120ME2000G	86.5 kg	166 x 31 x 43cm
SD6120ME2500G	96 kg	180 x 31 x 43cm
SD6120ME3000G	102.5 kg	190 x 31 x 43cm

CÓDIGO	Ø DESCARGA	POTENCIA	VOLTAJE	CORRIENTE	ETAPAS	FLUJO MÁXIMO	PRESIÓN MÁXIMA	PUNTO DE MAYOR EFICIENCIA
SD6120ME1000G	3"	10 HP	220 V ~ 60Hz 3Φ	35	3	15 l/s	69 m	10 l/s a 47 m
SD6120ME1500G	3"	15 HP	220 V ~ 60Hz 3Φ	49.7	5	15 l/s	118 m	10 l/s a 65 m
SD6120ME2000G	3"	20 HP	220 V ~ 60Hz 3Φ	64.9	7	15 l/s	166 m	10 l/s a 100 m
SD6120ME2500G	3"	25 HP	220 V ~ 60Hz 3Φ	79.4	9	15 l/s	211 m	10 l/s a 130 m
SD6120ME3000G	3"	30 HP	220 V ~ 60Hz 3Φ	93.8	10	15 l/s	237 m	10 l/s a 150 m

BOMBA SUMERGIBLE 6" | 120 GPM

Desempeño de altura



CLASE 10

1 año GARANTÍA



- Bombas sumergibles para pozos profundos.
- La más resistente a la arena en su categoría.
- Impulsores tipo flotantes fabricados en Noryl®.
- Difusores fabricados en policarbonato.
- Descarga y cople en acero inoxidable extra resistentes.
- Válvula check integrada.

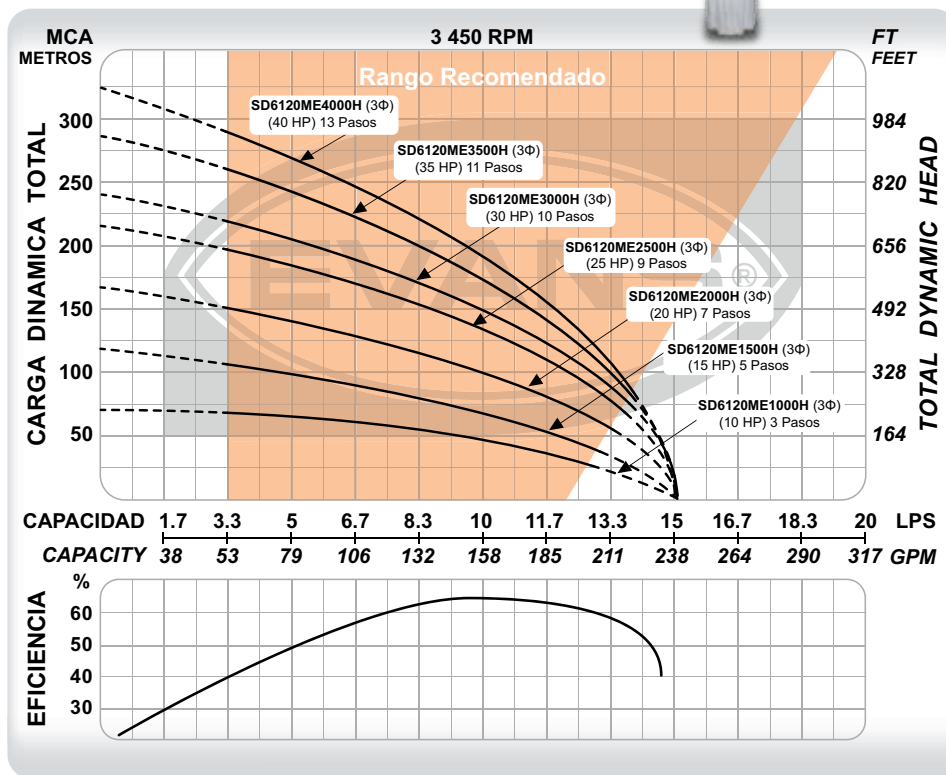

CÓDIGO	PESO	MEDIDAS
		LARGO x ANCHO x ALTO
SD6120ME1000H	66.5 kg	133 x 31 x 43 cm
SD6120ME1500H	75 kg	148 x 31 x 43 cm
SD6120ME2000H	86.5 kg	166 x 31 x 43 cm
SD6120ME2500H	96 kg	180 x 31 x 43 cm
SD6120ME3000H	102.5 kg	190 x 31 x 43 cm
SD6120ME3500H	110.5 kg	196 x 31 x 43 cm
SD6120ME4000H	118.6 kg	215 x 31 x 43 cm

CÓDIGO	Ø DESCARGA	POTENCIA	VOLTAJE	CORRIENTE	ETAPAS	FLUJO MÁXIMO	PRESIÓN MÁXIMA	PUNTO DE MAYOR EFICIENCIA
SD6120ME1000H	3"	10 HP	440 V ~ 60Hz 3Φ	17.5 A	3	15 l/s	69 m	10 l/s a 47 m
SD6120ME1500H	3"	15 HP	440 V ~ 60Hz 3Φ	24.8 A	5	15 l/s	118 m	10 l/s a 65 m
SD6120ME2000H	3"	20 HP	440 V ~ 60Hz 3Φ	32.4 A	7	15 l/s	166 m	10 l/s a 100 m
SD6120ME2500H	3"	25 HP	440 V ~ 60Hz 3Φ	39.7 A	9	15 l/s	211 m	10 l/s a 130 m
SD6120ME3000H	3"	30 HP	440 V ~ 60Hz 3Φ	46.9 A	10	15 l/s	237 m	10 l/s a 150 m
SD6120ME3500H	3"	35 HP	440 V ~ 60Hz 3Φ	58.7 A	11	15 l/s	280 m	10 l/s a 175 m
SD6120ME4000H	3"	40 HP	440 V ~ 60Hz 3Φ	65.2 A	13	15 l/s	325 m	10 l/s a 195 m



CLASE 10

BOMBA SUMERGIBLE INOXIDABLE 6" | 130 GPM

Desempeño de altura



- Bombas sumergibles para pozos profundos.
- La más eficiente en su categoría: mayor presión y flujo con menor consumo energético.
- Fabricación 100% en acero inoxidable 304.
- Válvula check integrada.



CÓDIGO	PESO	MEDIDAS LARGO x ANCHO x ALTO
SD6130ME1000GI	56 kg	159 x 31 x 43 cm
SD6130ME1500GI	67 kg	185 x 31 x 43 cm
SD6130ME2000GI	91 kg	221 x 31 x 43 cm
SD6130ME2500GI	98 kg	247 x 31 x 43 cm
SD6130ME3000GI	110 kg	272 x 31 x 43 cm
SD6130ME1000HI	56 kg	159 x 31 x 43 cm
SD6130ME1500HI	67 kg	185 x 31 x 43 cm
SD6130ME2000HI	91 kg	221 x 31 x 43 cm
SD6130ME2500HI	98 kg	247 x 31 x 43 cm
SD6130ME3000HI	110 kg	272 x 31 x 43 cm

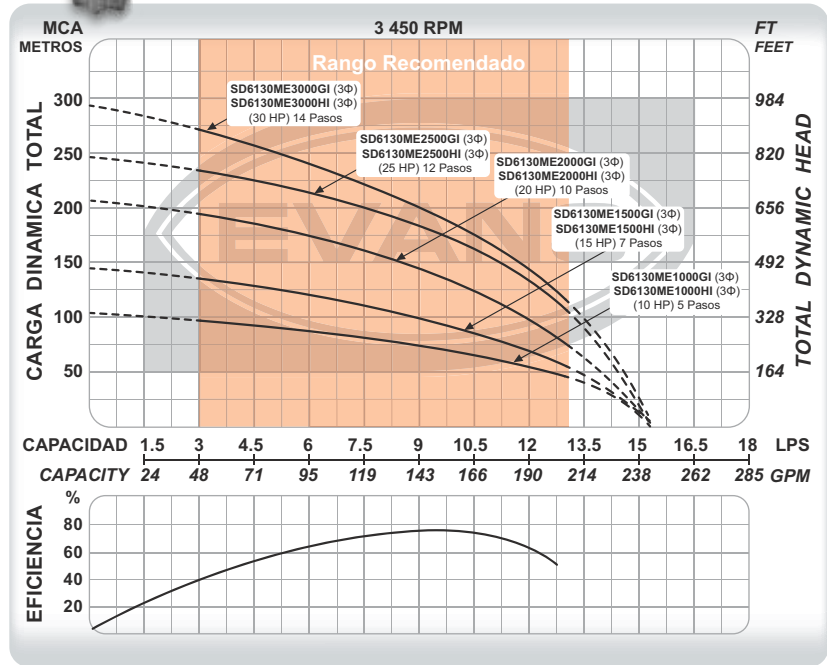

CÓDIGO	Ø DESCARGA	POTENCIA	VOLTAJE	CORRIENTE	ETAPAS	FLUJO MÁXIMO	PRESIÓN MÁXIMA	PUNTO DE MAYOR EFICIENCIA
SD6130ME1000GI	3"	10 HP	220 V ~ 60Hz 3Φ	35 A	5	15.5 l/s	103 m	9 l/s a 70 m
SD6130ME1500GI	3"	15 HP	220 V ~ 60Hz 3Φ	49.7 A	7	15.5 l/s	144 m	9 l/s a 95 m
SD6130ME2000GI	3"	20 HP	220 V ~ 60Hz 3Φ	64.9 A	10	15.5 l/s	207 m	9 l/s a 140 m
SD6130ME2500GI	3"	25 HP	220 V ~ 60Hz 3Φ	79.4 A	12	15.5 l/s	248 m	9 l/s a 180 m
SD6130ME3000GI	3"	30 HP	220 V ~ 60Hz 3Φ	93.8 A	14	15.5 l/s	289 m	9 l/s a 195 m
SD6130ME1000HI	3"	10 HP	440 V ~ 60Hz 3Φ	17.5 A	5	15.5 l/s	103 m	9 l/s a 70 m
SD6130ME1500HI	3"	15 HP	440 V ~ 60Hz 3Φ	24.8 A	7	15.5 l/s	144 m	9 l/s a 95 m
SD6130ME2000HI	3"	20 HP	440 V ~ 60Hz 3Φ	32.4 A	10	15.5 l/s	207 m	9 l/s a 140 m
SD6130ME2500HI	3"	25 HP	440 V ~ 60Hz 3Φ	39.7 A	12	15.5 l/s	248 m	9 l/s a 180 m
SD6130ME3000HI	3"	30 HP	440 V ~ 60Hz 3Φ	46.9 A	14	15.5 l/s	289 m	9 l/s a 195 m

BOMBA SUMERGIBLE INOXIDABLE 6" | 130 GPM

Desempeño de altura



CLASE 10

1
año
GARANTÍA



- Bombas sumergibles para pozos profundos.
- La más eficiente en su categoría: mayor presión y flujo con menor consumo energético.
- Fabricación 100% en acero inoxidable 304.
- Válvula check integrada.

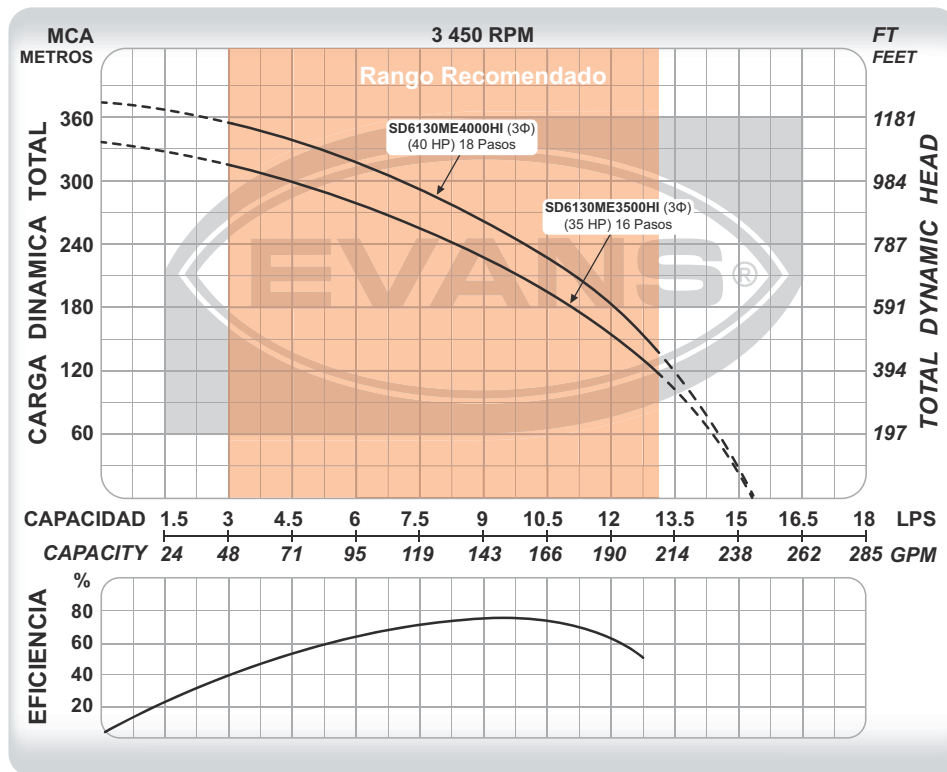

CÓDIGO	PESO	MEDIDAS LARGO x ANCHO x ALTO
SD6130ME3500HI	123 kg	296 x 31 x 43 cm
SD6130ME4000HI	134 kg	320 x 31 x 43 cm

CÓDIGO	Ø DESCARGA	POTENCIA	VOLTAJE	CORRIENTE	ETAPAS	FLUJO MÁXIMO	PRESIÓN MÁXIMA	PUNTO DE MAYOR EFICIENCIA
SD6130ME3500HI	3"	35 HP	440 V ~ 60Hz 3Φ	58.7 A	16	15.5 l/s	331 m	9 l/s a 225 m
SD6130ME4000HI	3"	40 HP	440 V ~ 60Hz 3Φ	65.2 A	18	15.5 l/s	373 m	9 l/s a 260 m

Desempeño de altura



- Bombas sumergibles para pozos profundos.
- La más resistente a la arena en su categoría.
- Impulsores tipo flotantes fabricados en Noryl®.
- Difusores fabricados en policarbonato.
- Descarga y cople en acero inoxidable extra resistentes.
- Válvula check integrada.

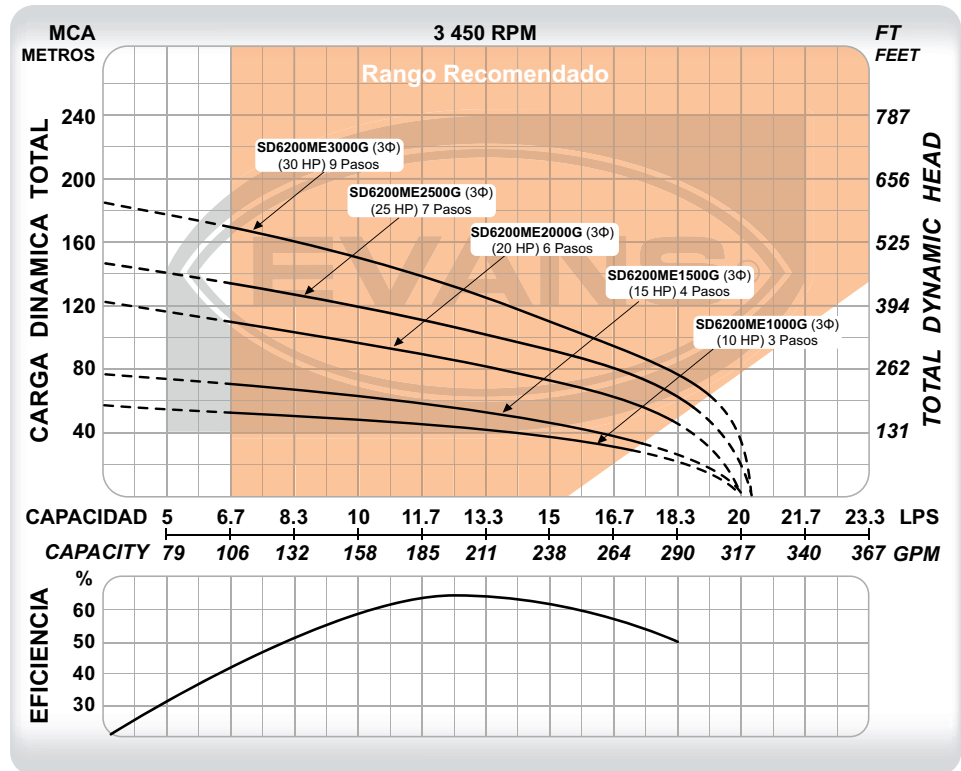

CÓDIGO	PESO	MEDIDAS LARGO x ANCHO x ALTO
SD6200ME1000G	66.5 kg	146 x 31 x 43 cm
SD6200ME1500G	77 kg	161 x 31 x 43 cm
SD6200ME2000G	88.5 kg	188 x 31 x 43 cm
SD6200ME2500G	98 kg	202 x 31 x 43 cm
SD6200ME3000G	105.5 kg	225 x 31 x 43 cm

CÓDIGO	Ø DESCARGA	POTENCIA	VOLTAJE	CORRIENTE	ETAPAS	FLUJO MÁXIMO	PRESIÓN MÁXIMA	PUNTO DE MAYOR EFICIENCIA
SD6200ME1000G	3"	10 HP	220 V ~ 60Hz 3Φ	35 A	3	20 l/s	58 m	13 l/s a 34 m
SD6200ME1500G	3"	15 HP	220 V ~ 60Hz 3Φ	49.7 A	4	20 l/s	77 m	13 l/s a 50 m
SD6200ME2000G	3"	20 HP	220 V ~ 60Hz 3Φ	64.9 A	6	20 l/s	120 m	13 l/s a 80 m
SD6200ME2500G	3"	25 HP	220 V ~ 60Hz 3Φ	79.4 A	7	20 l/s	145 m	13 l/s a 100 m
SD6200ME3000G	3"	30 HP	220 V ~ 60Hz 3Φ	93.8 A	9	20 l/s	183 m	13 l/s a 130 m

BOMBA SUMERGIBLE 6" | 200 GPM

Desempeño de altura

CLASE 10



1
año
GARANTÍA



- Bombas sumergibles para pozos profundos.
- La más resistente a la arena en su categoría.
- Impulsores tipo flotantes fabricados en Noryl®.
- Difusores fabricados en policarbonato.
- Descarga y cople en acero inoxidable extra resistentes.
- Válvula check integrada.

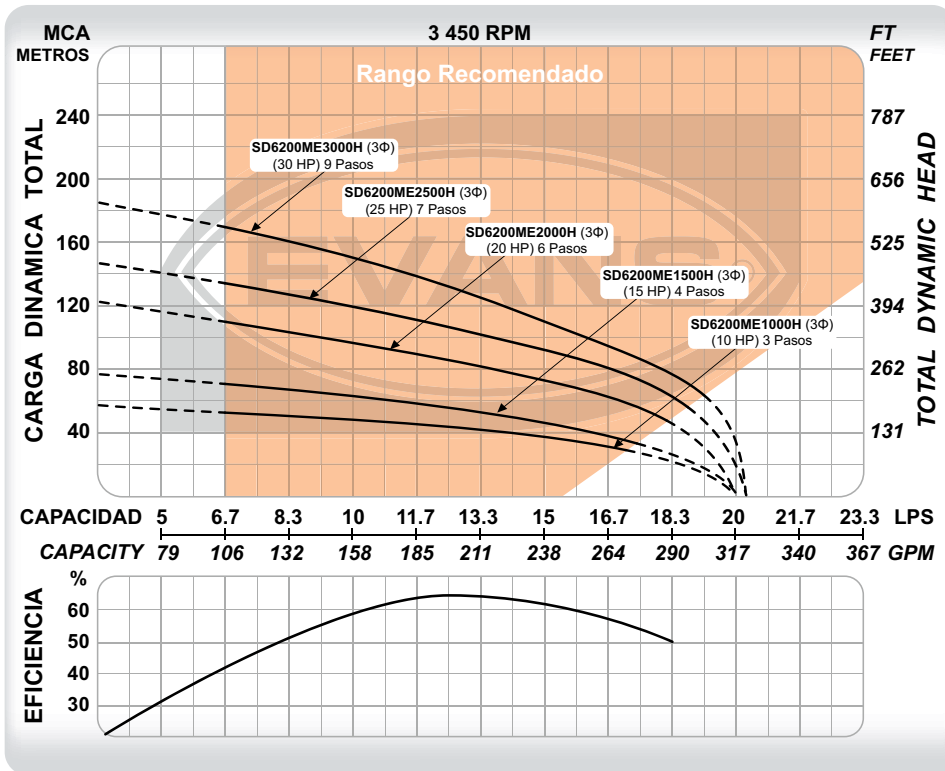

CÓDIGO	PESO	MEDIDAS LARGO x ANCHO x ALTO
SD6200ME1000H	66.5 kg	146 x 31 x 43 cm
SD6200ME1500H	77 kg	161 x 31 x 43 cm
SD6200ME2000H	88.5 kg	188 x 31 x 43 cm
SD6200ME2500H	98 kg	202 x 31 x 43 cm
SD6200ME3000H	105.5 kg	225 x 31 x 43 cm

CÓDIGO	Ø DESCARGA	POTENCIA	VOLTAJE	CORRIENTE	ETAPAS	FLUJO MÁXIMO	PRESIÓN MÁXIMA	PUNTO DE MAYOR EFICIENCIA
SD6200ME1000H	3"	10 HP	440 V ~ 60Hz 3Φ	17.5 A	3	20 l/s	58 m	13 l/s a 34 m
SD6200ME1500H	3"	15 HP	440 V ~ 60Hz 3Φ	24.8 A	4	20 l/s	77 m	13 l/s a 60 m
SD6200ME2000H	3"	20 HP	440 V ~ 60Hz 3Φ	32.4 A	6	20 l/s	120 m	13 l/s a 82 m
SD6200ME2500H	3"	25 HP	440 V ~ 60Hz 3Φ	39.7 A	7	20 l/s	145 m	13 l/s a 100 m
SD6200ME3000H	3"	30 HP	440 V ~ 60Hz 3Φ	46.9 A	9	20 l/s	183 m	13 l/s a 130 m



CLASE 10

BOMBA SUMERGIBLE 6" | 200 GPM

Desempeño de altura



- Bombas sumergibles para pozos profundos.
- La más resistente a la arena en su categoría.
- Impulsores tipo flotantes fabricados en Noryl®.
- Difusores fabricados en policarbonato.
- Descarga y cople en acero inoxidable extra resistentes.
- Válvula check integrada.

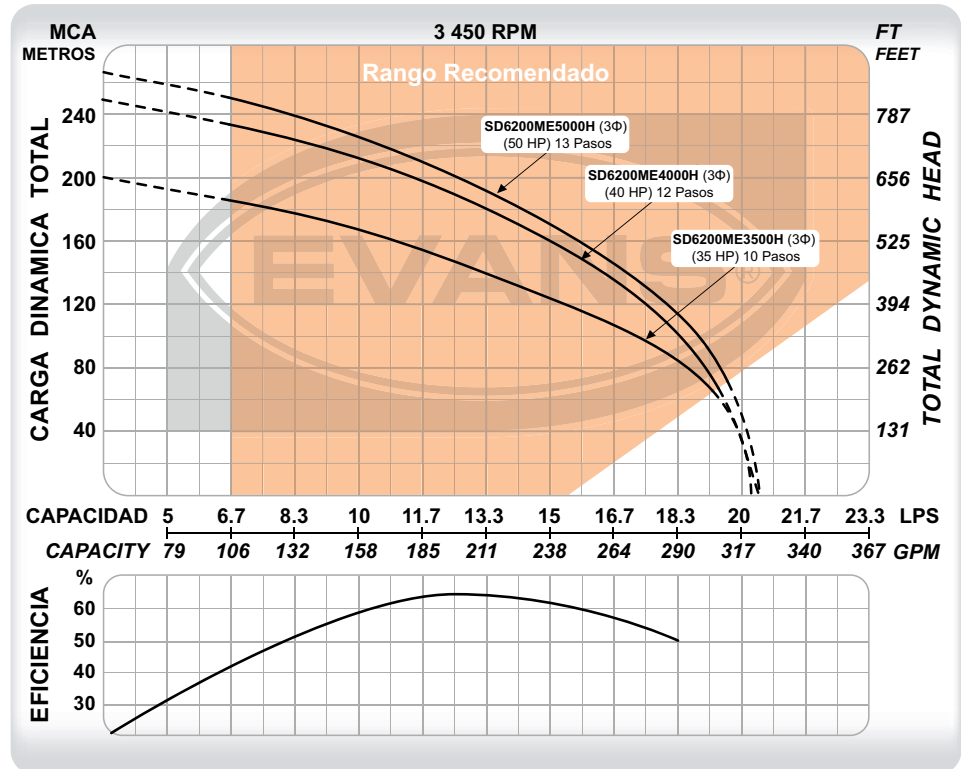

CÓDIGO	PESO	MEDIDAS LARGO x ANCHO x ALTO
SD6200ME3500H	114.5 kg	239 x 31 x 43 cm
SD6200ME4000H	123.6 kg	262 x 31 x 43 cm
SD6200ME5000H	140 kg	280 x 31 x 43 cm

CÓDIGO	Ø DESCARGA	POTENCIA	VOLTAJE	CORRIENTE	ETAPAS	FLUJO MÁXIMO	PRESIÓN MÁXIMA	PUNTO DE MAYOR EFICIENCIA
SD6200ME3500H	3"	35 HP	440 V ~ 60Hz 3Φ	58.7 A	10	20 l/s	198 m	13 l/s a 145 m
SD6200ME4000H	3"	40 HP	440 V ~ 60Hz 3Φ	65.2 A	12	20 l/s	248 m	13 l/s a 180 m
SD6200ME5000H	3"	50 HP	440 V ~ 60Hz 3Φ	86.3 A	13	20 l/s	263 m	13 l/s a 190 m

BOMBA SUMERGIBLE INOXIDABLE 6" | 200 GPM

Desempeño de altura



CLASE 10

1
año
GARANTÍA



- Bombas sumergibles para pozos profundos.
- La más eficiente en su categoría: mayor presión y flujo con menor consumo energético.
- Fabricación 100% en acero inoxidable 304.
- Válvula check integrada.

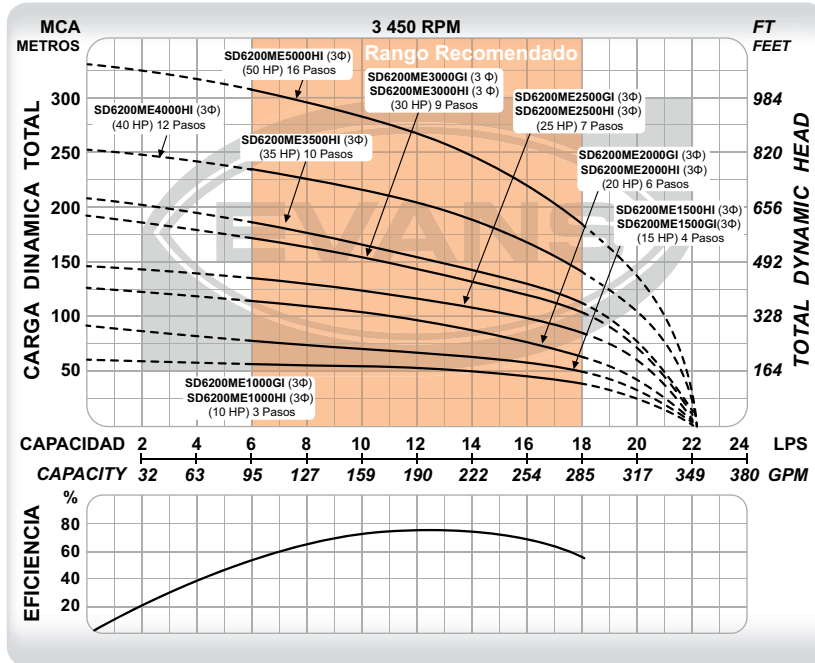

CÓDIGO	PESO	MEDIDAS LARGO x ANCHO x ALTO
SD6200ME1000GI	54 kg	145 x 31 x 43 cm
SD6200ME1500GI	63 kg	163 x 31 x 43 cm
SD6200ME2000GI	85 kg	193 x 31 x 43 cm
SD6200ME2500GI	90 kg	211 x 31 x 43 cm
SD6200ME3000GI	104 kg	239 x 31 x 43 cm
SD6200ME1000HI	54 kg	145 x 31 x 43 cm
SD6200ME1500HI	63 kg	163 x 31 x 43 cm
SD6200ME2000HI	85 kg	193 x 31 x 43 cm
SD6200ME2500HI	90 kg	211 x 31 x 43 cm
SD6200ME3000HI	104 kg	239 x 31 x 43 cm
SD6200ME3500HI	115 kg	239 x 31 x 43 cm
SD6200ME4000HI	126 kg	255 x 31 x 43 cm
SD6200ME5000HI	140 kg	280 x 31 x 43 cm

CÓDIGO	Ø DESCARGA	POTENCIA	VOLTAJE	CORRIENTE	ETAPAS	FLUJO MÁXIMO	PRESIÓN MÁXIMA	PUNTO DE MAYOR EFICIENCIA
SD6200ME1000GI	4"	10 HP	220 V ~ 60Hz 3Φ	35 A	3	22 l/s	62 m	12 l/s a 50 m
SD6200ME1500GI	4"	15 HP	220 V ~ 60Hz 3Φ	49.7 A	4	22 l/s	83 m	12 l/s a 65 m
SD6200ME2000GI	4"	20 HP	220 V ~ 60Hz 3Φ	64.9 A	6	22 l/s	125 m	12 l/s a 95 m
SD6200ME2500GI	4"	25 HP	220 V ~ 60Hz 3Φ	79.4 A	7	22 l/s	146 m	12 l/s a 115 m
SD6200ME3000GI	4"	30 HP	220 V ~ 60Hz 3Φ	93.8 A	9	22 l/s	188 m	12 l/s a 140 m
SD6200ME1000HI	4"	10 HP	440 V ~ 60Hz 3Φ	17.5 A	3	22 l/s	62 m	12 l/s a 50 m
SD6200ME1500HI	4"	15 HP	440 V ~ 60Hz 3Φ	24.8 A	4	22 l/s	83 m	12 l/s a 65 m
SD6200ME2000HI	4"	20 HP	440 V ~ 60Hz 3Φ	32.4 A	6	22 l/s	125 m	12 l/s a 95 m
SD6200ME2500HI	4"	25 HP	440 V ~ 60Hz 3Φ	39.7 A	7	22 l/s	146 m	12 l/s a 115 m
SD6200ME3000HI	4"	30 HP	440 V ~ 60Hz 3Φ	46.9 A	9	22 l/s	188 m	12 l/s a 140 m
SD6200ME3500HI	4"	35 HP	440 V ~ 60Hz 3Φ	58.7 A	10	22 l/s	209 m	12 l/s a 155 m
SD6200ME4000HI	4"	40 HP	440 V ~ 60Hz 3Φ	65.2 A	12	22 l/s	250 m	12 l/s a 205 m
SD6200ME5000HI	4"	50 HP	440 V ~ 60Hz 3Φ	86.3 A	16	22 l/s	330 m	12 l/s a 270 m



CLASE 10

BOMBA SUMERGIBLE INOXIDABLE 6" | 270 GPM

Desempeño de altura



- Bombas sumergibles para pozos profundos.
- La más eficiente en su categoría: mayor presión y flujo con menor consumo energético.
- Fabricación 100% en acero inoxidable 304.
- Válvula check integrada.

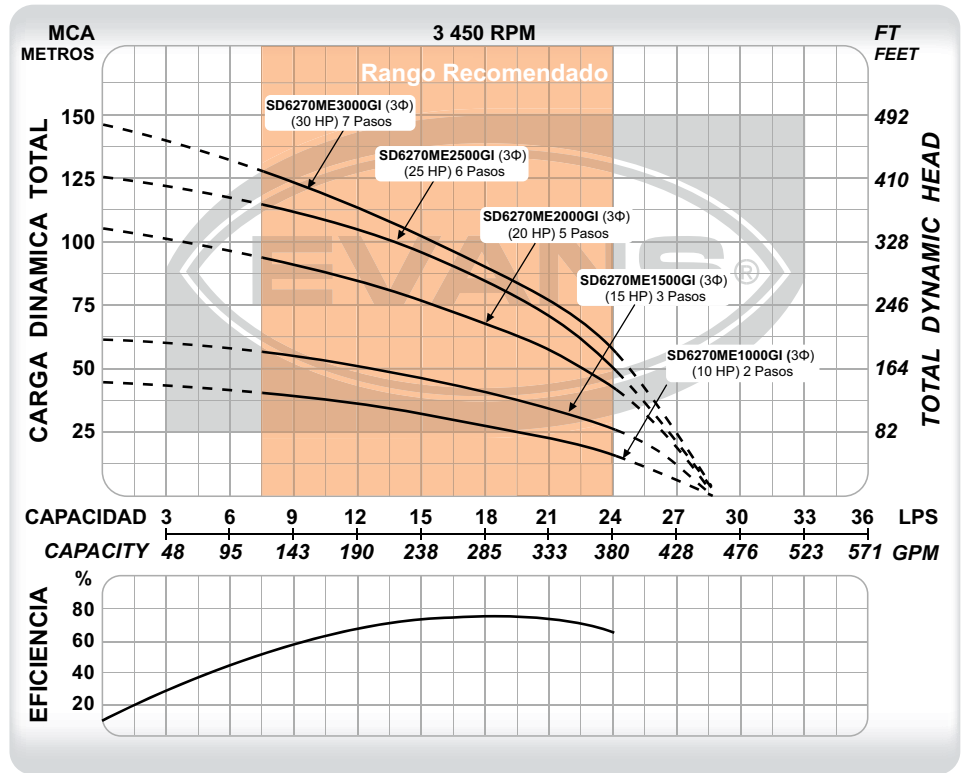

CÓDIGO	PESO	MEDIDAS LARGO x ANCHO x ALTO
SD6270ME1000GI	51 kg	134 x 31 x 43 cm
SD6270ME1500GI	61 kg	152 x 31 x 43 cm
SD6270ME2000GI	82 kg	181 x 31 x 43 cm
SD6270ME2500GI	88 kg	199 x 31 x 43 cm
SD6270ME3000GI	98 kg	217 x 31 x 43 cm

CÓDIGO	Ø DESCARGA	POTENCIA	VOLTAJE	CORRIENTE	ETAPAS	FLUJO MÁXIMO	PRESIÓN MÁXIMA	PUNTO DE MAYOR EFICIENCIA
SD6270ME1000GI	4"	10 HP	220 V ~ 60Hz 3Φ	35 A	2	28.5 l/s	41 m	18 l/s a 25 m
SD6270ME1500GI	4"	15 HP	220 V ~ 60Hz 3Φ	49.7 A	3	28.5 l/s	62 m	18 l/s a 38 m
SD6270ME2000GI	4"	20 HP	220 V ~ 60Hz 3Φ	64.9 A	5	28.5 l/s	104 m	18 l/s a 65 m
SD6270ME2500GI	4"	25 HP	220 V ~ 60Hz 3Φ	79.4 A	6	28.5 l/s	125 m	18 l/s a 85 m
SD6270ME3000GI	4"	30 HP	220 V ~ 60Hz 3Φ	93.8 A	7	28.5 l/s	145 m	18 l/s a 92 m

BOMBA SUMERGIBLE INOXIDABLE6" | 270 GPM

Desempeño de altura



CLASE 10

1 año GARANTÍA



- Bombas sumergibles para pozos profundos.
- La más eficiente en su categoría: mayor presión y flujo con menor consumo energético.
- Fabricación 100% en acero inoxidable 304.
- Válvula check integrada.

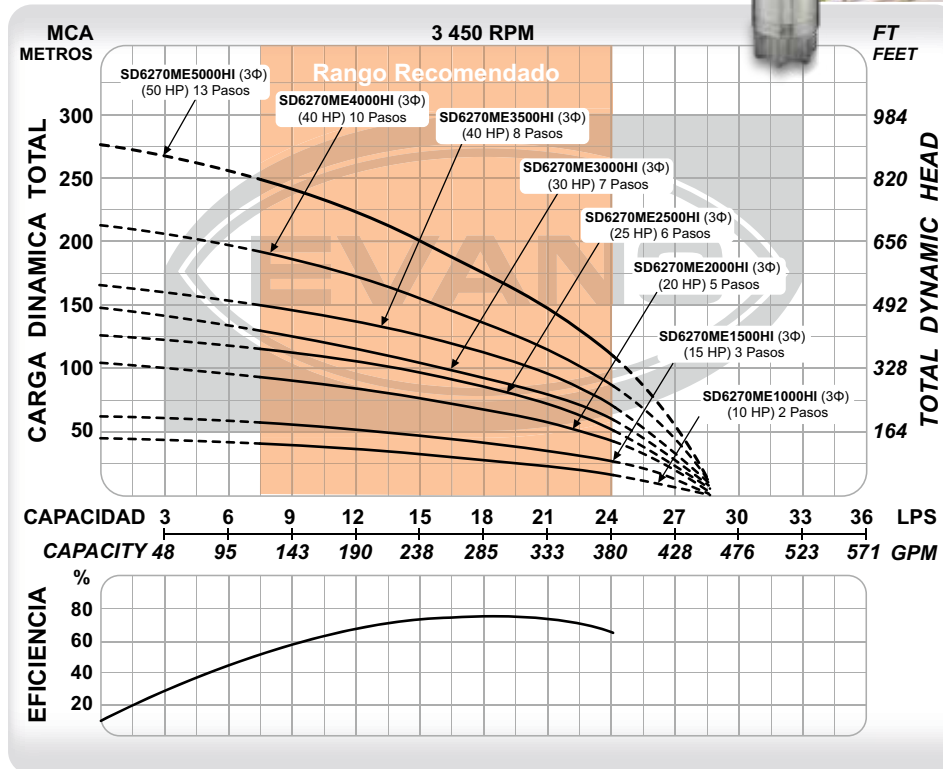

CÓDIGO	PESO	MEDIDAS LARGO x ANCHO x ALTO
SD6270ME1000HI	51 kg	134 x 31 x 43 cm
SD6270ME1500HI	61 kg	152 x 31 x 43 cm
SD6270ME2000HI	82 kg	181 x 31 x 43 cm
SD6270ME2500HI	88 kg	199 x 31 x 43 cm
SD6270ME3000HI	98 kg	217 x 31 x 43 cm
SD6270ME3500HI	109 kg	233 x 31 x 43 cm
SD6270ME4000HI	122 kg	260 x 31 x 43 cm
SD6270ME5000HI	142 kg	285 x 31 x 43 cm

CÓDIGO	Ø DESCARGA	POTENCIA	VOLTAJE	CORRIENTE	ETAPAS	FLUJO MÁXIMO	PRESIÓN MÁXIMA	PUNTO DE MAYOR EFICIENCIA
SD6270ME1000HI	4"	10 HP	440 V ~ 60Hz 3Φ	17.5 A	2	28.5 l/s	41 m	18 l/s a 25 m
SD6270ME1500HI	4"	15 HP	440 V ~ 60Hz 3Φ	24.8 A	3	28.5 l/s	62 m	18 l/s a 38 m
SD6270ME2000HI	4"	20 HP	440 V ~ 60Hz 3Φ	32.4 A	5	28.5 l/s	104 m	18 l/s a 65 m
SD6270ME2500HI	4"	25 HP	440 V ~ 60Hz 3Φ	39.7 A	6	28.5 l/s	125 m	18 l/s a 85 m
SD6270ME3000HI	4"	30 HP	440 V ~ 60Hz 3Φ	46.9 A	7	28.5 l/s	145 m	18 l/s a 92 m
SD6270ME3500HI	4"	35 HP	440 V ~ 60Hz 3Φ	58.7 A	8	28.5 l/s	166 m	18 l/s a 113 m
SD6270ME4000HI	4"	40 HP	440 V ~ 60Hz 3Φ	65.2 A	10	28.5 l/s	211 m	18 l/s a 135 m
SD6270ME5000HI	4"	50 HP	440 V ~ 60Hz 3Φ	86.3 A	13	28.5 l/s	275 m	18 l/s a 175 m

La tubería de columna en UPVC es una opción excelente para equipar pozos profundos ya que disminuye las pérdidas por fricción, elimina problemas de oxidación y reduce el peso y costo de la instalación. Su rosca cuadrada tiene mayor superficie de sujeción que la NPT y cada tramo incluye un o-ring interno para asegurar el correcto sellado de estos.

No requiere selladores ni herramientas para su instalación.

EJEMPLO DE INSTALACIÓN

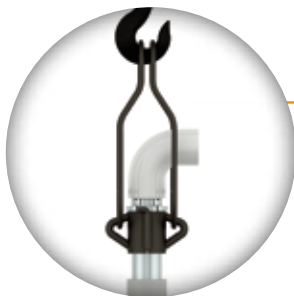

Adaptador de columna/ red hidráulica

Adaptador superior que convierte de rosca cuadrada a NPT y clamp de sujeción para maniobras.



Kit de adaptadores

También se pueden utilizar para instalar una válvula check entre tramos de UPVC. Recomendamos una válvula check cada 50m ó 16 tramos.

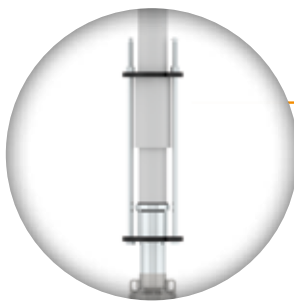

Arnes de sujeción y adaptador bomba/ columna

Adaptador inferior que convierte de rosca NPT a rosca cuadrada y arnés de sujeción para asegurar la bomba.

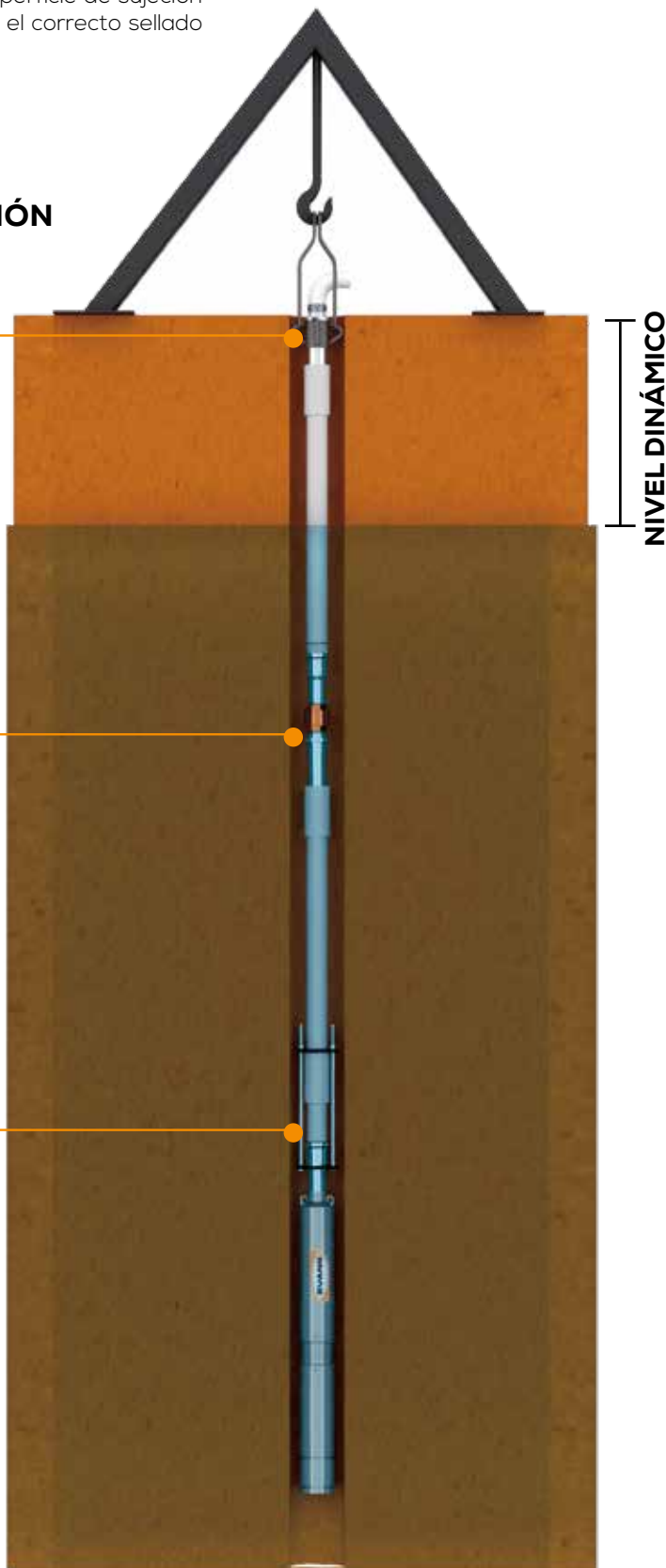



TUBO DE COLUMNA UPVC MACHO /HEMбра, ROSCA CUADRADA CON O-RING INTEGRADO. TRAMOS DE 2.8m DE LARGO

CÓDIGOS	Ø DE CONEXIÓN	CARGA MÁXIMA	ESPESSOR	PRESIÓN MÁXIMA	CARGA DE ROTURA
● UPVC125-100M	1.25"	100 m	4.2 mm	20 (kg/cm ²)	2000 kg
● UPVC125-250M	1.25"	250 m	6.1 mm	30 (kg/cm ²)	3500 kg
● UPVC200-100M	2"	100 m	4.95 mm	20 (kg/cm ²)	3100 kg
● UPVC200-350M	2"	350 m	7.65 mm	35 (kg/cm ²)	4800 kg
● UPVC300-100M	3"	100 m	6.35 mm	30 (kg/cm ²)	5500 kg
● UPVC300-150M	3"	150 m	7.8 mm	35 (kg/cm ²)	7200 kg
● UPVC300-350M	3"	350 m	10.15 mm	40 (kg/cm ²)	10000 kg
● UPVC400-100M	4"	100 m	6.68 mm	30 (kg/cm ²)	7800 kg
● UPVC400-150M	4"	150 m	8.4 mm	35 (kg/cm ²)	12000 kg
● UPVC400-350M	4"	350 m	12.15 mm	40 (kg/cm ²)	18000 kg

La relación de colores indica compatibilidad entre componentes.



KIT DE CONECTORES PARA ADAPTAR EL PRIMER TRAMO DE TUBERÍA CON LA DESCARGA DE LA BOMBA Y EL ÚLTIMO CON LA RED HIDRÁULICA.

CÓDIGOS	Ø DE CONEXIÓN	CARGA MÁXIMA	MATERIALES
● KIT125-HG150	1.25"	150 m	Hierro gris
● KIT200-HG150	2"	150 m	
● KIT300-HG150	3"	150 m	
● KIT400-HG150	4"	150 m	
● KIT125-SS150	1.25"	150 m	Acero inoxidable
● KIT200-SS150	2"	150 m	
● KIT300-SS150	3"	150 m	
● KIT400-SS150	4"	150 m	
● KIT125-SS250	1.25"	250 m	
● KIT400-SS450	4"	450 m	



ARNES DE SUJECIÓN PARA LA BOMBA

CÓDIGOS	Ø DE CONEXIÓN
● KIT200-ARNES	2"
● KIT300-ARNES	3"
● KIT400-ARNES	4"



ABRAZADERA EN HIERRO GRIS PARA MANIOBRAR BOMBA ACOPLADA A TUBO DE COLUMNA

CÓDIGOS	Ø DE CONEXIÓN
CLAMP125	1.25"
CLAMP200	2"
CLAMP300	3"
CLAMP400	4"



LLAVE CON CORREA AJUSTABLE

CÓDIGO	Ø DE SUJECIÓN
LLAVE-EVANS	1.25" - 6"



Los arrancadores por variador de frecuencia están especialmente diseñados para accionar bombas sumergibles de pozo profundo con arranque suave, evitando picos de corriente durante el arranque, ahorrando así energía y alargando la vida útil del motor por reducir su desgaste.

Usando estos gabinetes en aplicaciones sin acceso a energía eléctrica de la red pública donde sea necesario utilizar un generador, este no se sobredimensiona tanto en comparación con arranque a tensión plena o inclusive arranque suave convencional. Reduciendo exponencialmente el tamaño del generador y la inversión necesaria para accionar la bomba.

Se cuentan con 2 versiones: la versión "50M" para casos donde la longitud del conductor que conecta el motor y el gabinete NO excede los 50m y otra para cuando esta distancia sea mayor, la cual soporta hasta 500m. La versión "500M", incluye un filtro de tipo dv/dt, para atenuar los armónicos generados naturalmente en grandes distancias por las variaciones de frecuencia.

Ambas versiones se surten con flotador para controlar el llenado de depósitos, electrodos para proteger la bomba contra corrida en seco por pozo abatido, así como protecciones por caída de fase, corto circuito y sobre voltaje.

El equipo se surte con un gabinete termoplástico con ventilación y grado de protección IP55.

Para conocer la corriente de alimentación y corriente máxima de salida del equipo, consulte la sección de variador/ inversor EVANS-SOLAR® (página 135).

ATENCIÓN: ESTE EQUIPO INCLUYE UN VARIADOR DE FRECUENCIA CUYA FUNCIÓN ES ARRANCAR LA BOMBA CON RAMPA DE ACELERACIÓN SUAVE POR MEDIO DE FRECUENCIA VARIABLE. SIN EMBARGO ESTE VARIADOR NO SE PUEDE INSTALAR CON TRANSDUCTOR DE FRECUENCIA Y SUMINISTRAR PRESIÓN CONSTANTE. EL VARIADOR QUE SE INCLUYE ES DE LA FAMILIA EVANS-SOLAR.

AB - AVF 5 G - 50M

1 2 3 4 5

1 ACCESORIO BOMBA

2 ARRANCADOR POR VARIADOR DE FRECUENCIA

3 POTENCIA DE LA BOMBA

5	5 HP 3Φ	25	25 HP 3Φ
7.5	7.5 HP 3Φ	30	30 HP 3Φ
10	10 HP 3Φ	40	40 HP 3Φ
15	15 HP 3Φ	50	50 HP 3Φ
20	20 HP 3Φ		

4 VOLTAJE

G	220V ~ 60 Hz
H	440V ~ 60 Hz

5 DISTANCIA MÁXIMA ENTRE EL GABINETE Y LA BOMBA

50 M	50 metros
500 M	500 metros

